

6. Disassembly and Reassembly

6.1 Cautions When Replacing Parts	page(6-2)
6.1.1 Cautions when assembling and disassembling	page(6-2)
6.1.2 Cautions when handling PBA	page(6-2)
6.2 Parts for Maintenance and Repair	page(6-3)
6.2.1 Replacing cycle of parts for maintenance and repair	page(6-3)
6.2.2 Printer Cleaning	page(6-4)
6.3 Information Related in Disassembly and Assembly	page(6-5)
6.3.1 Attentional item when disassembling or assembling	page(6-5)
1) Disassemble of LSU Unit	page(6-5)
2) Disassemble of ITB Unit	page(6-5)
3) Custody of OPC Unit	page(6-5)
4) Custody of Toner Cartridge	page(6-5)
5) Disassemble of DEVE Drive Ass'y and Main Drive Ass'y	page(6-5)
6) Disassemble of Terminal Parts	page(6-5)
7) Disassemble of Fuser Unit	page(6-5)
6.3.2 Screw Used in the Printer	page(6-6)
6.3.3 Various Cover Open and Consumption Part' Disassembly	page(6-7)
>> Consumption Parts' disassembly	page(6-7)
6.3.4 Replacing the Waste Toner Tank	page(6-10)
>> Disassembling the waste toner tank	page(6-10)
6.4 Process of Disassembly	page(6-12)
6.4.1 Top Cover and Front Cover	page(6-12)
6.4.2 OP Panel Ass'y	page(6-16)
6.4.3 Rear Cover	page(6-17)
6.4.4 Duplex Cover Ass'y and Transfer Roller (T2) Roller	page(6-19)
6.4.5 Fuser	page(6-21)
6.4.6 Exit Cover	page(6-23)
6.4.7 SMPS and Main PBA	page(6-24)
6.4.8 Fuser Fan	page(6-27)
6.4.9 Main Drive Ass'y	page(6-28)
6.4.10 HVPS (High Voltage Power Supply)	page(6-30)
6.4.11 DEVE Drive Ass'y	page(6-32)
6.4.12 DEVE Drive PBA and DEVE Cover Open S/W	page(6-34)
6.4.13 DEVE Drive Motor and ITB Cleaning Solenoid	page(6-36)
6.4.14 Erase lamp	page(6-37)
6.4.15 DEVE Cover	page(6-38)
6.4.16 LSU Unit	page(6-39)
6.4.17 DEVE OEM PBA	page(6-41)
6.4.18 Waste Toner Ass'y	page(6-42)
6.4.19 MPT(Multi Purpose Tray)	page(6-44)
6.4.20 Pick-Up Ass'y	page(6-45)

6.1 Precautions when replacing parts

6.1.1 Precautions when assembling and disassembling

- * Use only approved Samsung spare parts. Ensure that part number, product name, any voltage, current or temperature rating are correct. Failure to do so could result in damage to the machine, circuit overload, fire or electric shock.
- * Do not make any unauthorized changes or additions to the printer, these could cause the printer to malfunction and create electric shock or fire hazards.
- * Take care when dismantling the unit to note where each screw goes. There are 19 different screws. Use of the wrong screw could lead to system failure, short circuit or electric shock.
- * Do not disassemble the LSU unit. Once it is disassembled dust is admitted to the mirror chamber and will seriously degrade print quality. There are no serviceable parts inside.
- * Regularly check the condition of the power cord, plug and socket. Bad contacts could lead to overheating and fire. Damaged cables could lead to electric shock or unit malfunction.

6.1.2 Precautions when handling PBA

Static electricity can damage a PBA, always use approved anti-static precautions when handling or storing a PBA.

>> Precautions when moving and storing PBA

1. Please keep PBA in a conductive case, anti-static bag, or wrapped in aluminum foil.
2. Do not store a PBA where it is exposed to direct sunlight.

>> Precautions when replacing PBA

1. Disconnect power connectors first, before disconnecting other cables
2. Do not touch any soldered connections, connector terminals or other electronic parts when handling insulated parts.

>> Precautions when checking PBA

1. Before touching a PBA, please touch other grounded areas of the chassis to discharge any static electrical charge on the body.
2. Take care not to touch the PBA with your bare hands or metal objects as you could create a short circuit or get an electric shock. Take extra care when handling PBAs with moving parts fitted such as sensors, motors or lamps as they may get hot.
3. Take care when fitting, or removing, screws. Look out for hidden screws. Always ensure that the correct screw is used and always ensure that when toothed washers are removed they are refitted in their original positions.

6.1.3 Releasing Plastic Latches

Many of the parts are held in place with plastic latches. The latches break easily; release them carefully.

To remove such parts, press the hook end of the latch away from the part to which it is latched.

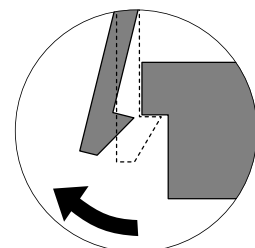

6.2 Parts for Maintenance and Repair

6.2.1 Replacing cycle of parts for maintenance and Repair

Some of the parts in this printer have a limited life, shorter than that of the whole machine. These parts must be replaced periodically.

The table below shows the interval at which these parts should be replaced.

The table shows the life of each part, and is measured when using A4 paper. When servicing a machine always check the status of these parts using the control panel and ensure that parts are replaced at the appropriate times otherwise a general degradation in print quality will occur.

COMPONENT	REPLACEMENT CYCLE	REMARK
Toer Cartridge(Black)	initial(2,000 pages@5% coverage) replacement(7,000 pages@5% coverage)	User replace
Toer Cartridge(Cyan)	initial(1,500 pages@5% coverage) replacement(5,000 pages@5% coverage)	User replace
Toer Cartridge(Magenta)	initial(1,500 pages@5% coverage) replacement(5,000 pages@5% coverage)	User replace
Toer Cartridge(Yellow)	initial(1,500 pages@5% coverage) replacement(5,000 pages@5% coverage)	User replace
OPC Unit	mono : 50,000 pages color : 12,500 pages	User replace
ITB Unit(T1 Roller)	mono : 50,000 pages color : 12,500 pages	User replace
Waste Toner Tank	3,000 Images	User replace
Fuser Unit	simplex : 100,000 pages duplex : 50,000 pages	Engineer
Transfer Roller(T2 Roller)	simplex : 50,000 pages duplex : 25,000 pages	Engineer

* Page: Counted value based on sides of paper printed (Duplex = 2 pages).

* Image: Counted value based on printed monochrome images.

* When printing a color section 1 page = 4 images. (i.e. each side is made up of 4 color images)

The life span of each of these parts is stored in memory. The amount of each 'life' used can be checked at any time using the control panel.

When a part is replaced it is necessary to reset the 'life used' that is stored in memory.

* How to initialize a the value of part's life span:

From the control panel, select the following items in order:

Menu-Setup - Maintenance - Check other - (Select a desired part) - Reset

6.2.2 Printer Cleaning

A printer should be regularly cleaned, especially if it is used in a dusty environment. This will ensure that print quality remains high and failure due to contamination of printing services is less likely to occur.

- * Clean the printer with a soft, lint free, cloth dipped in a "Recommended cleaner"
"Recommended cleaner" can be purchased from our service center. (where available)
- * Do not touch the transfer roller when cleaning the inside of the printer. Grease and oils from the skin will contaminate the surface and reduce print quality.
- * Do not touch transfer roller when cleaning inside of machine. If transfer roller gets dirty, printing quality could be low.
- * Please refer to the User Manual for cleaning instructions.

6.3 Information Related to Disassembly and Assembly.

6.3.1 Special service parts

Never disassemble or adjust the items mentioned, a stock of these items should be maintained.

1) Disassembly of the LSU unit

There are no serviceable parts inside the LSU. Alignment of the mirrors is critical. Opening the LSU will allow dust into the laser and significantly reduce print quality. It is very dangerous to operate or service a machine with the LSU open or system interlocks disabled. Exposure to laser radiation can cause blindness.

2) Disassembly of the ITB unit

Do not disassemble the ITB. The alignment of the home sensor is critical and is set up in the factory on a special jig. Incorrect re-assembly will cause print quality degradation.

3) Care of the OPC unit

If an OPC unit is exposed to direct sunlight for a long time the parameters and response of the electrostatic surface are changed causing image transfer and print quality issues. Also there is no protective shutter on the OPC drum to prevent scratching. Please take extra care to ensure the OPC drum is protected from sunlight and physical contact when servicing the machine.

4) Care of the Toner cartridge

Toner cartridges contain an extremely fine powder. Please keep toner cartridges away from children. The toner powder contained in the toner cartridge may be harmful and if swallowed you should contact a doctor. Take care not to spill toner - spillages should be cleaned with a vacume cleaner and washed in cold water (hot water sets the toner). Do not touch the developer roller surface as contamination will reduce print quality. Take care not to damage the roller's surface when installing or removing a toner cartridge.

5) Disassembly of DEVE drive ass'y and the main drive ass'y

The alignment of the drive mechanism is critical and it has been set up in factory using a jig and a driving gear. It is adjusted for the best gearing alignment. If the motor is disassembled alignment would not be maintained and this could cause operational noise and image problems: image alignment and toner distribution may be affected.

6) Disassembly of terminal parts









Do not adjust the variable resistors on the PBA. They have been already adjusted in the factory.

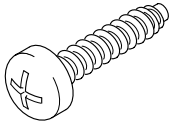



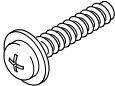

7) Disassembly of the fuser unit

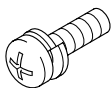
- The fuser melts toner onto the paper at a high temperature: therefore, you need to take special care not to get burned by a hot fuser. When removing the fuser from a set that has recently been operating you need to take extra care.
- Do not touch an AC line (Copper contact) on a main frame even after removing the fuser.

6.3.2 Screws used in the printer

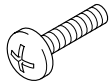
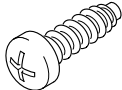
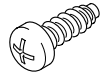
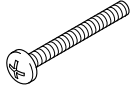
The screws listed in the table below are used in this printer. Please ensure that, when you disassemble the printer, you keep a note of which screw is used for which part and that, when reassembling the printer, the correct screws are used in the appropriate places.

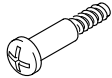
NO	DESCRIPTION	SEC CODE	SPEC
S1	SCREW-MACHINE	6001-000485	2.6*4, GOLD
			
S2	SCREW-TAPPING	6002-000115	4*15, GOLD
			
S3	SCREW-TAPPING	6002-000175	3*8, GOLD
			
S4	SCREW-TAPTITE	6002-000308	2.6*6, GOLD
			
S5	SCREW-TAPTITE	6003-000119	3*8, BLACK
			
S6	SCREW-TAPTITE	6003-000152	2*10, GOLD
			
S7	SCREW-TAPTITE	6003-000179	3*6, GOLD
			
S8	SCREW-TAPTITE	6003-000196	3*10 SILVER
			
S9	SCREW-TAPTITE	6003-000266	3*6, GOLD
			
S10	SCREW-ASS'Y MACH	6006-001193	3*6, GOLD
			

NO	DESCRIPTION	SEC CODE	SPEC
S11	SCREW-TAPTITE	6003-000269	3*6, GOLD
			
S12	SCREW-TAPTITE	6003-001001	3*8, BLACK
			
S13	SCREW-MACHINE	6001-000568	3*8, SILVER
			
S14	SCREW-TAPTITE	6003-001256	4*10 SILVER
			
S15	SCREW-TAPTITE	6003-000261	3*6, GOLD
			
S16	SCREW-MACHINE	6003-001068	2*16, BLACK
			
S17	SCREW-TAPTITE	6003-000301	4*6, GOLD
			
S18	SCREW-SPICIAL	6009-001396	3*10, BLACK
			
S19	SCREW-TAPTITE	6003-000008	4*6, SILVER
			

6.3.3 Opening Covers and replacing Consumable parts

This section shows you how to open the covers (front cover, DEVE cover, exit cover, and duplex cover) and how to remove and replace the consumable parts (toner cartridge, ITB unit, and OPC drum).

>> Consumable parts removal

- 1) Pull the side handle to open the DEVE cover and then press down firmly until the toner cartridges are ejected.



Caution: Before opening the exit cover, completely open the DEVE cover (eject the toner cartridges)

- 2) Removing a toner cartridge (K, Y, M, and C)

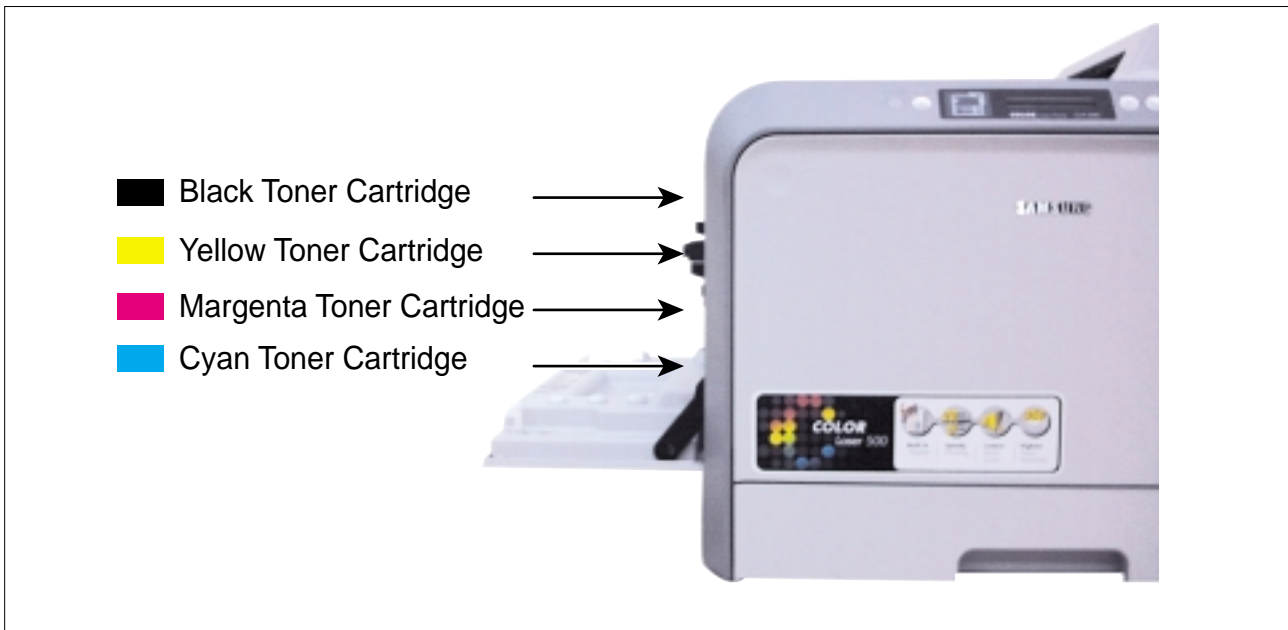

Caution: * Take care not to damage the rollers.
* Keep the toner cartridge on a flat surface.

3) Open the exit cover by pressing the cover open button.

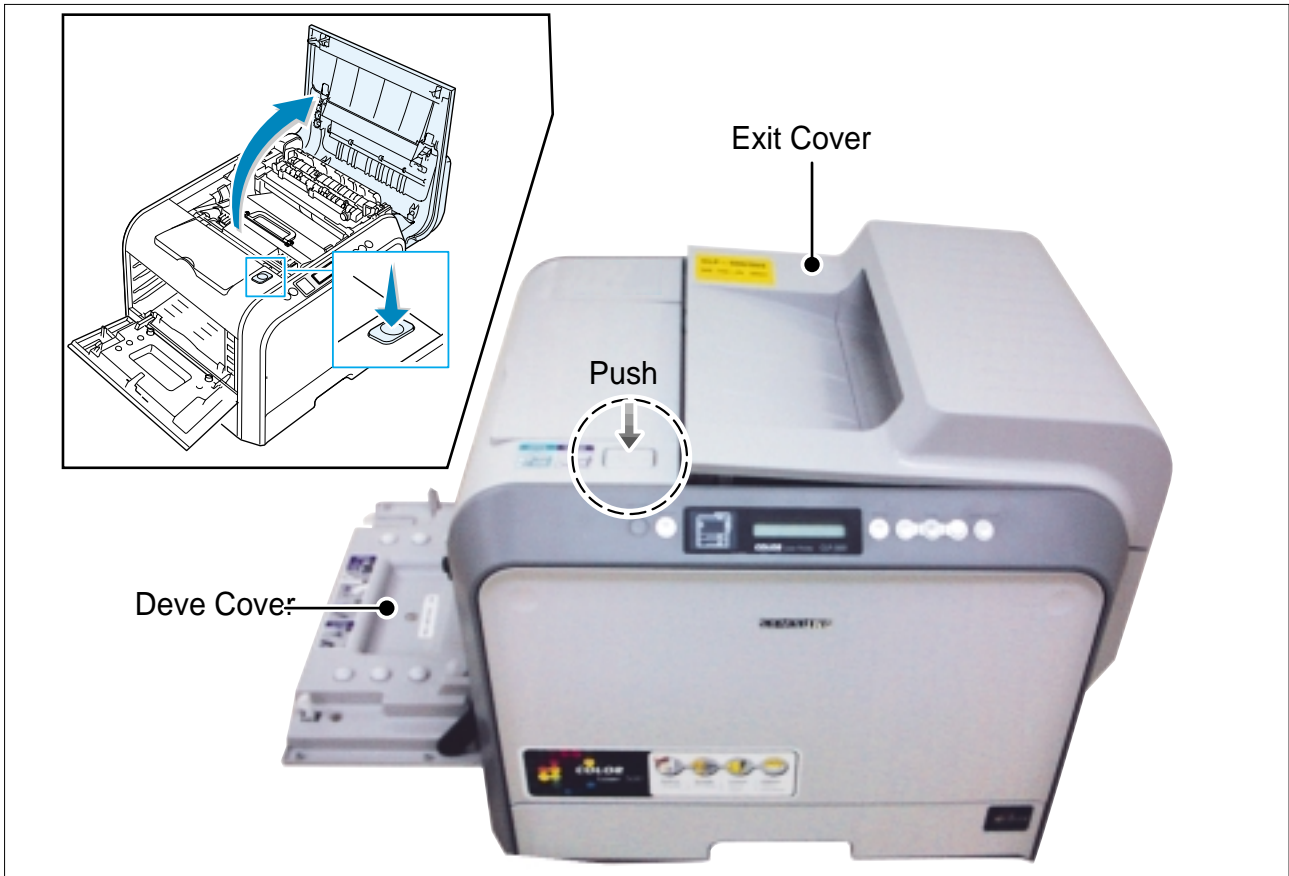

Caution: Before opening the exit over completely open the DEVE cover until it is at right angles to the main frame and the toner cartridges are ejected

4) Remove the ITB unit by releasing the ITB lock levers on both sides of the unit.

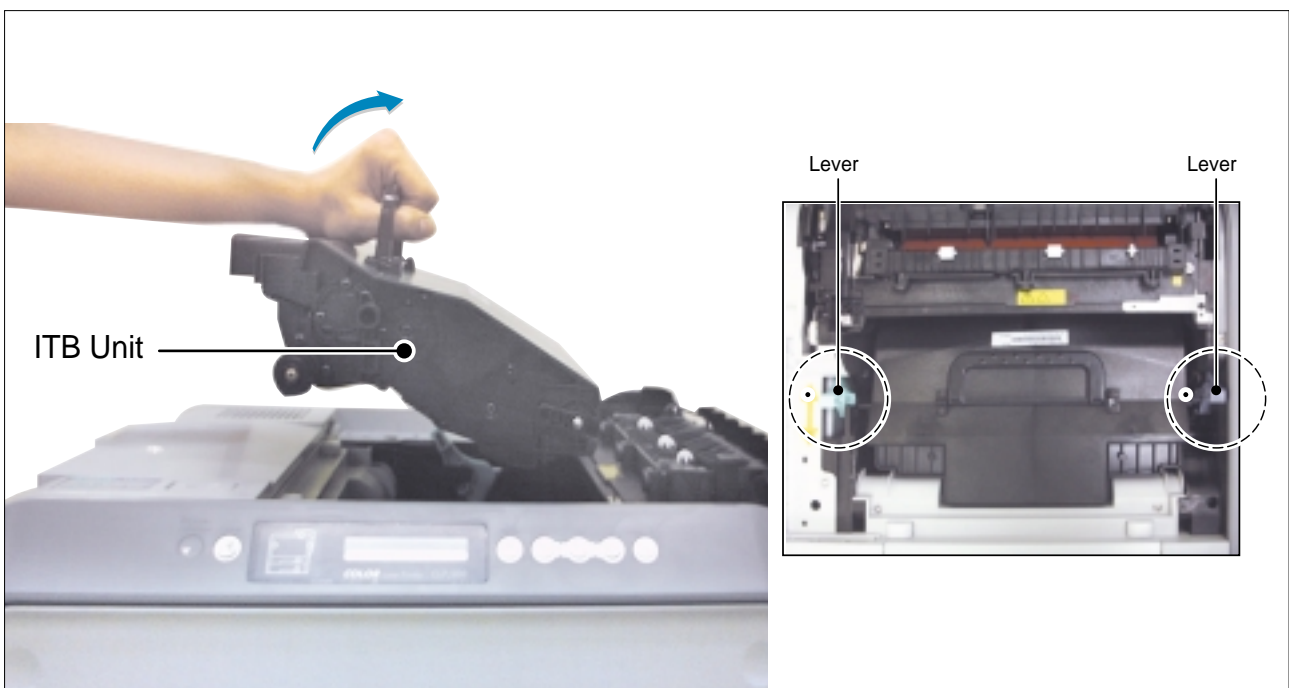

- 5) Remove the OPC drum by carefully lifting the unit using the handle provided. Take care to ensure that the OPC drum surface is not scratched or damaged. Do not touch the surface of the drum when lifting the drum handle or when removing the drum.

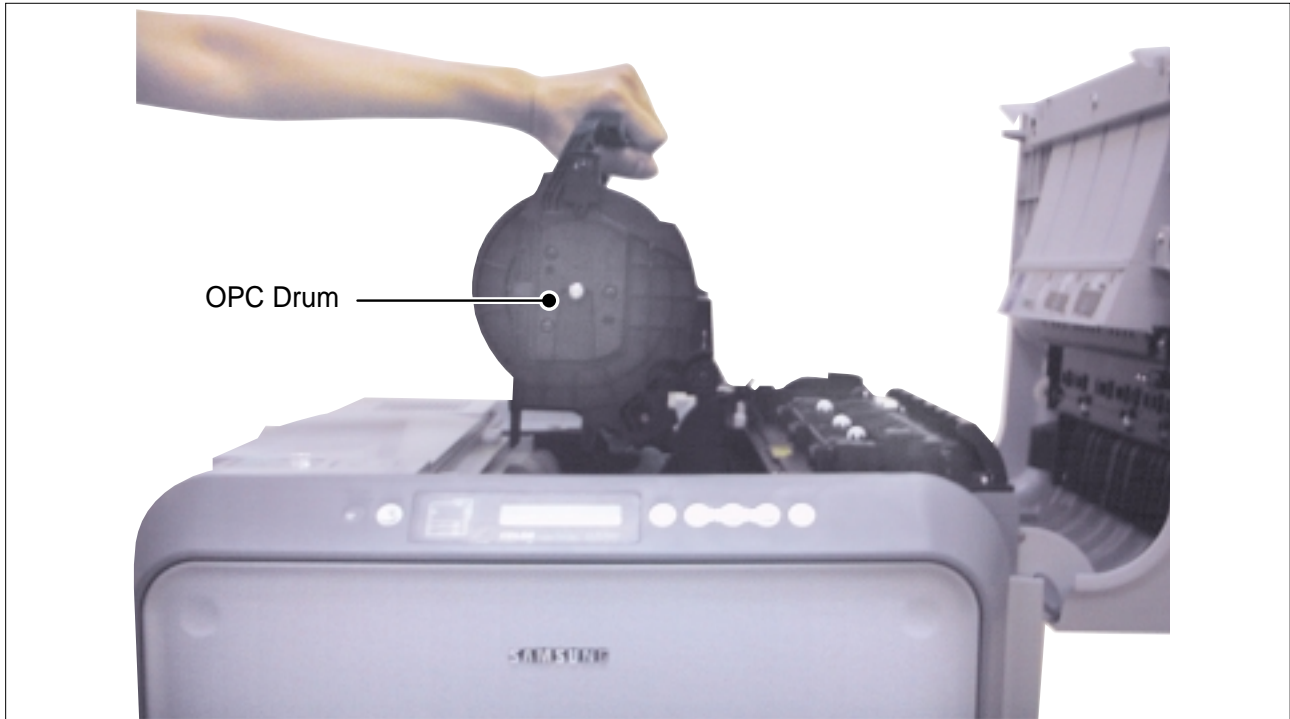

Caution: The surface of the OPC drum could be damaged if the OPC drum is exposed to direct sunlight for more than 5 minutes.

6.3.4 Replacing the Waste Toner Tank

>> Removing the waste toner tank

1) Push the top corners of the front cover to release the cover catches.



2) Lift the hook at the top of the waste toner tank and gently pull the top edge of the waste tank forward. Lift the tank out.

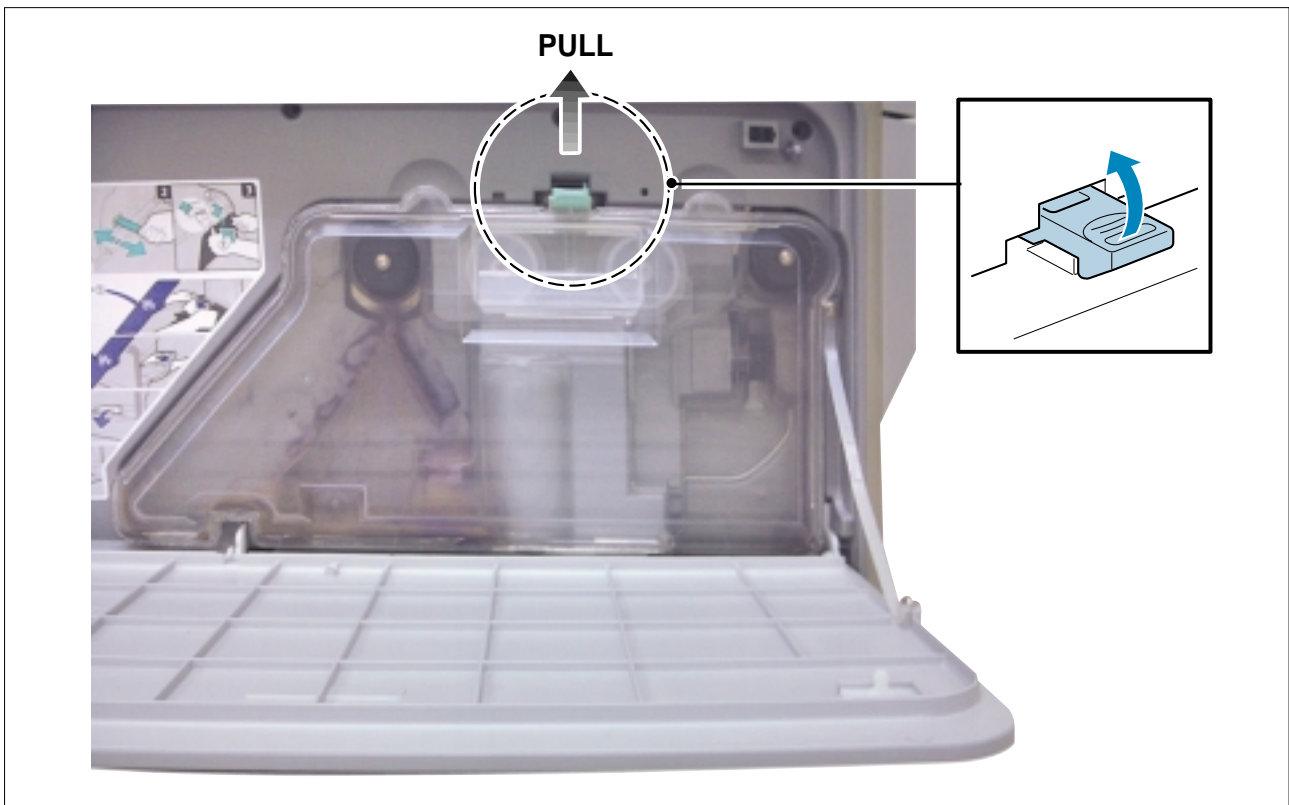

Caution: Be careful not to let toner spill from the waste toner tank.

3) Remove the Toner Caps from the side of the tank and fit them to the tank inlets as shown below

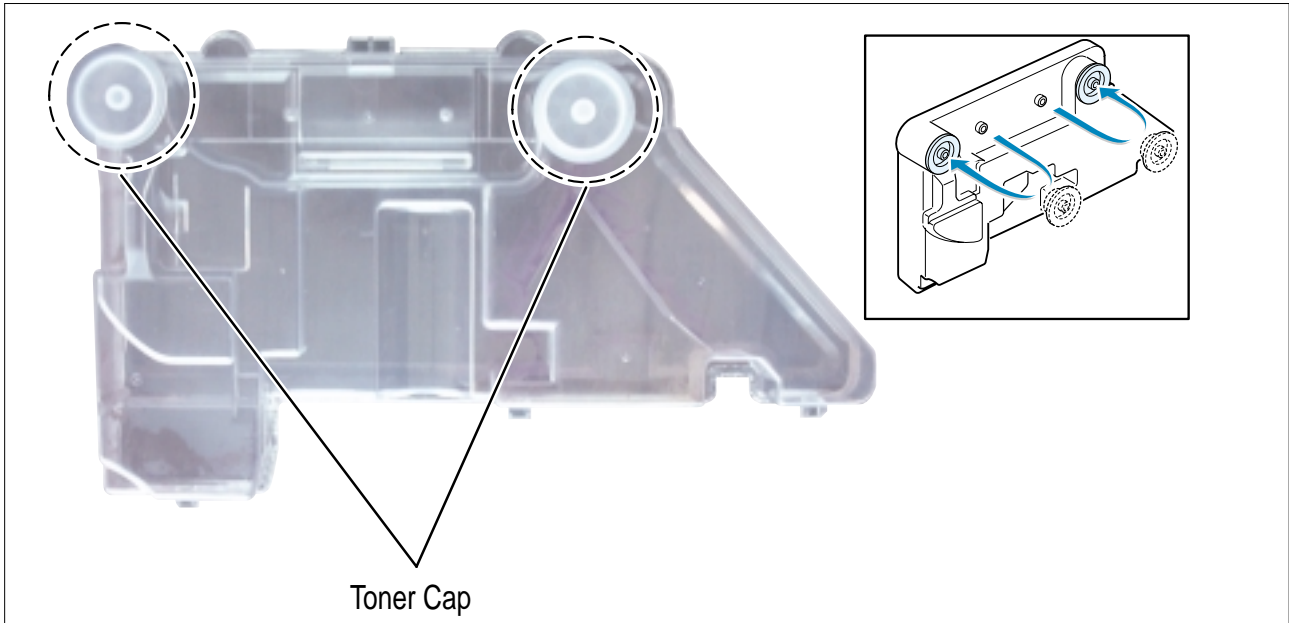

4) Fit a new waste toner tank.

6.4 Disassembly Procedure

6.4.1 Top cover and Front cover

1) Remove the cassette.



2) Open all of the covers in the following order:- Duplex cover - DEVE cover - Exit cover (Refer to 6.3.3)



3) Release 2 screws (3*10 silver).

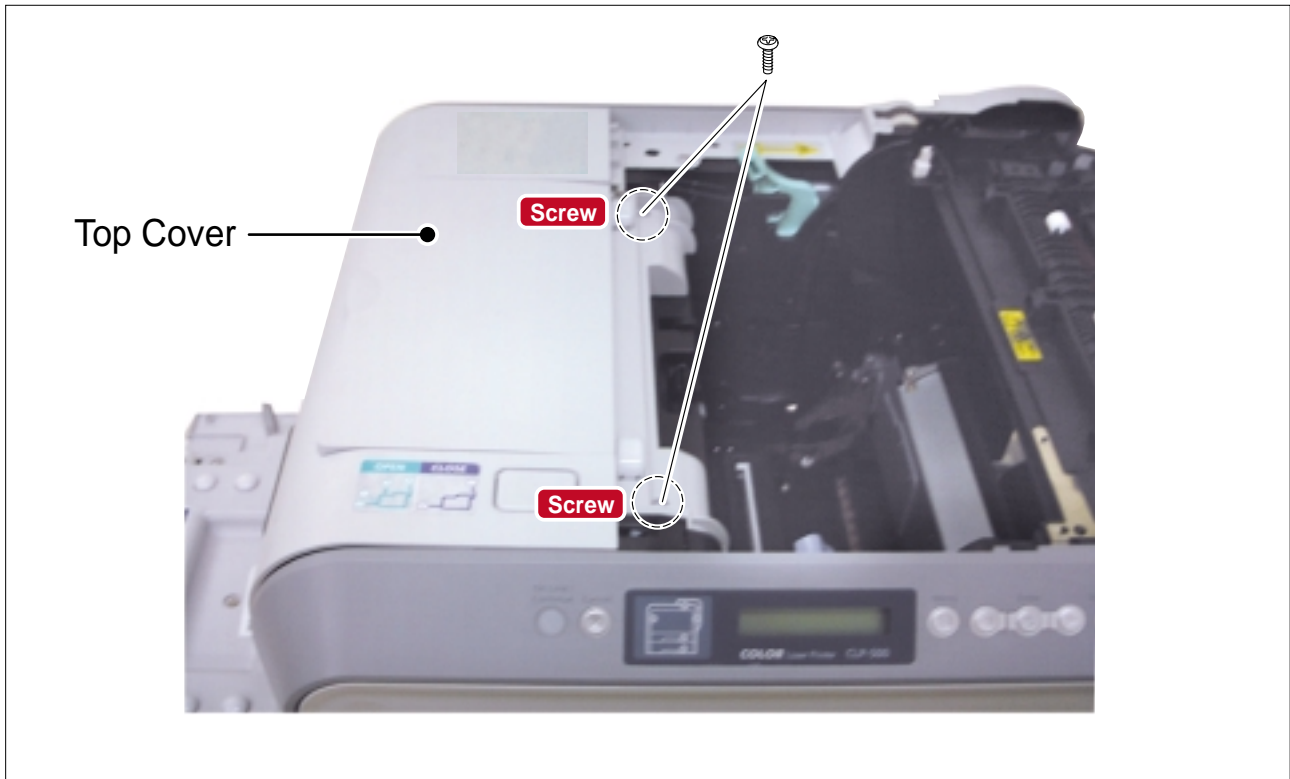

4) Take out the Top Cover as shown below.



- 5) Push both of the top corners to release the catches and open the front cover and then remove the waste toner tank. (Refer to 6.3.4)



- 6) Release 7 screws (3*10 silver) located inside the front cover.
Release 2 screws (3*10 silver) located on the top of the front cover.

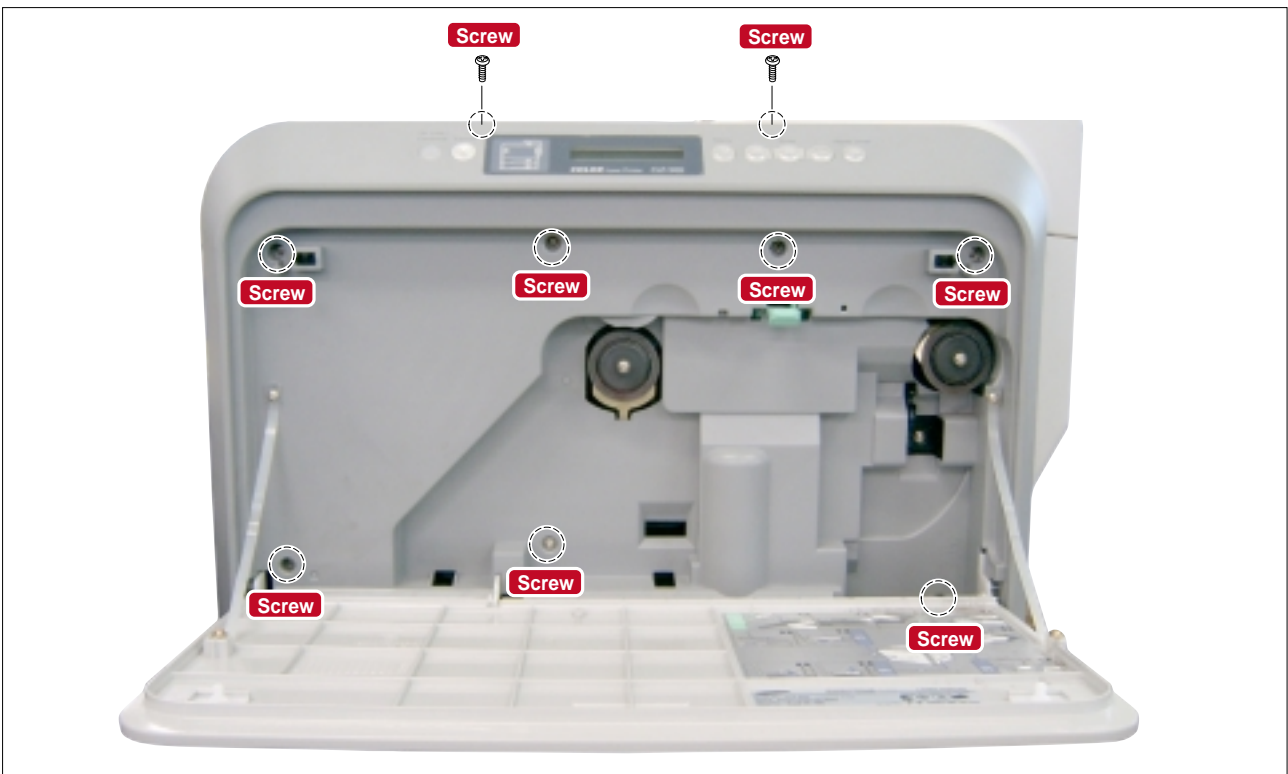

- 7) Release 2 hooks on the right and the left side with a flat bladed screwdriver and then remove the front cover. Take care to disconnect one harness connected to the frame.



6.4.2 OP Panel Ass'y

>> Before disassembling it: Remove the front cover. (Refer to 6.4.1)

- 1) Release 3 screws ('A' below 3*8 black) and take out the OP panel ass'y.
- 2) Release 4 screws ('B' below 3*8 black) from the Panel PBA and remove the panel PBA.
- 3) Release 2 screws ('C' below 3*6 gold) from the LCD and then take out the LCD.

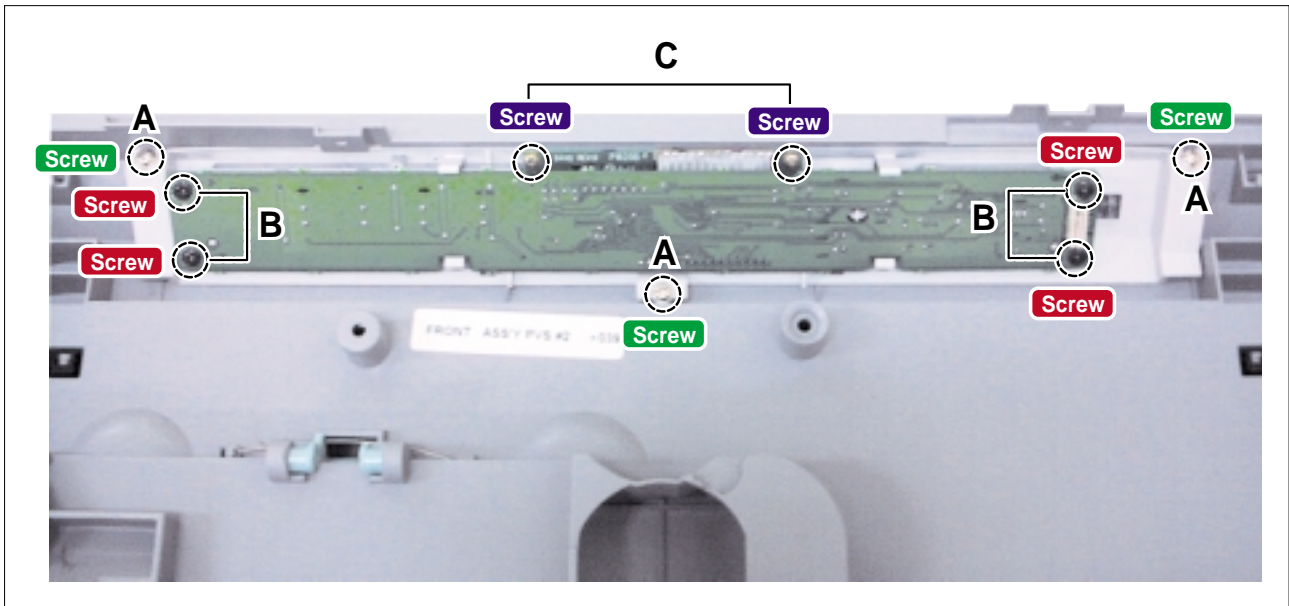

- A : OP Panel Screw, 3 * 8 Black
- B : Panel PBA Screw, 3 * 8 Black
- C : LCD Screw, 3 * 6 Yellow

6.4.3 Rear Cover

>> Before disassembling it:

*Open the **duplex cover**, the **DEVE cover** and the **exit cover**. (Refer to 6.3.3)
Remove the **top cover**. (Refer to 6.4.1)

- 1) Remove 10 screws.
A: Top 2 EA (3 * 10 Silver)
B: Side 3 EA (3 * 10 Silver)
C: Bottom 3 EA (4 * 10 Silver)
D: Rear 2 EA (3 * 10 Silver)

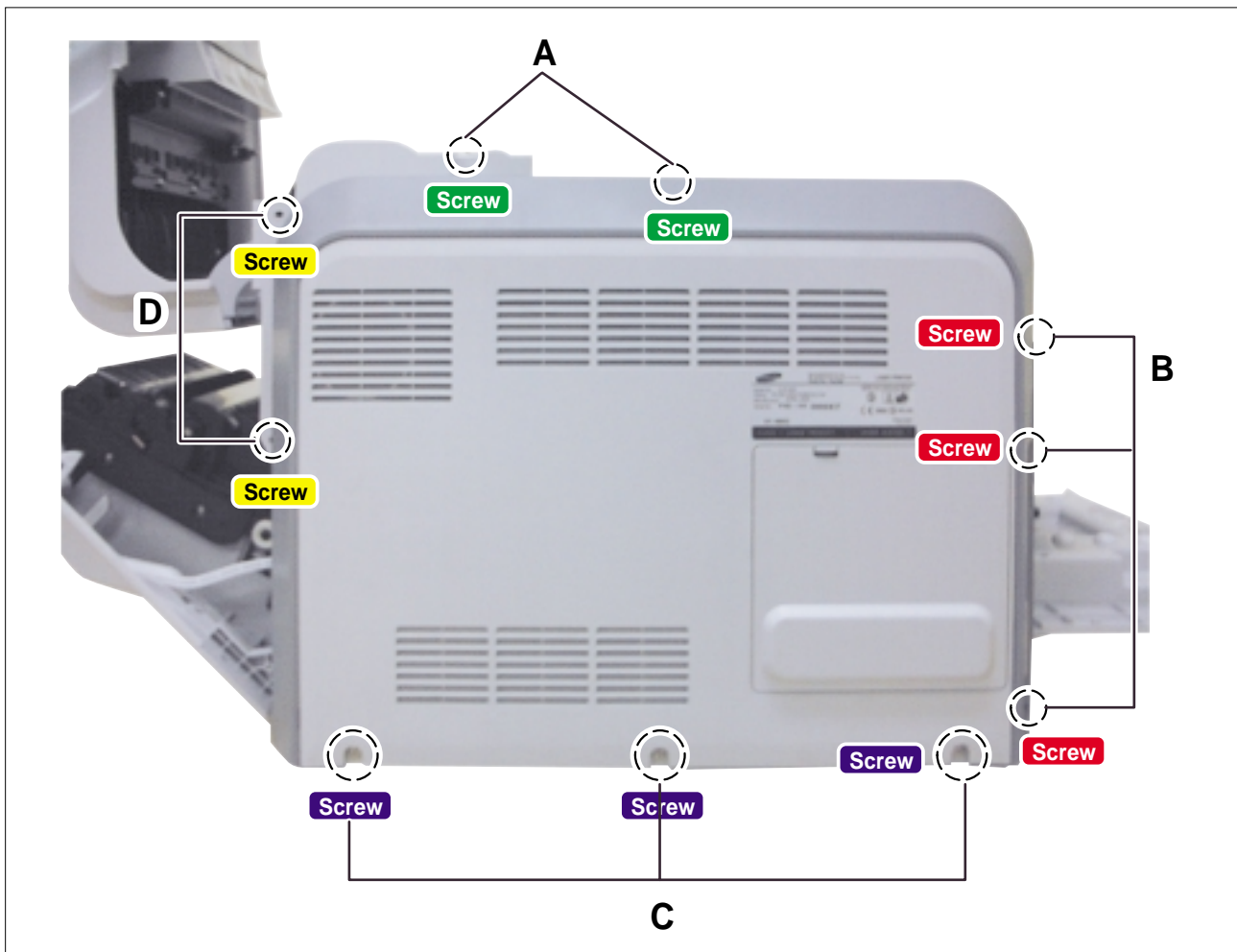

2) Take out the Rear Cover as shown below.

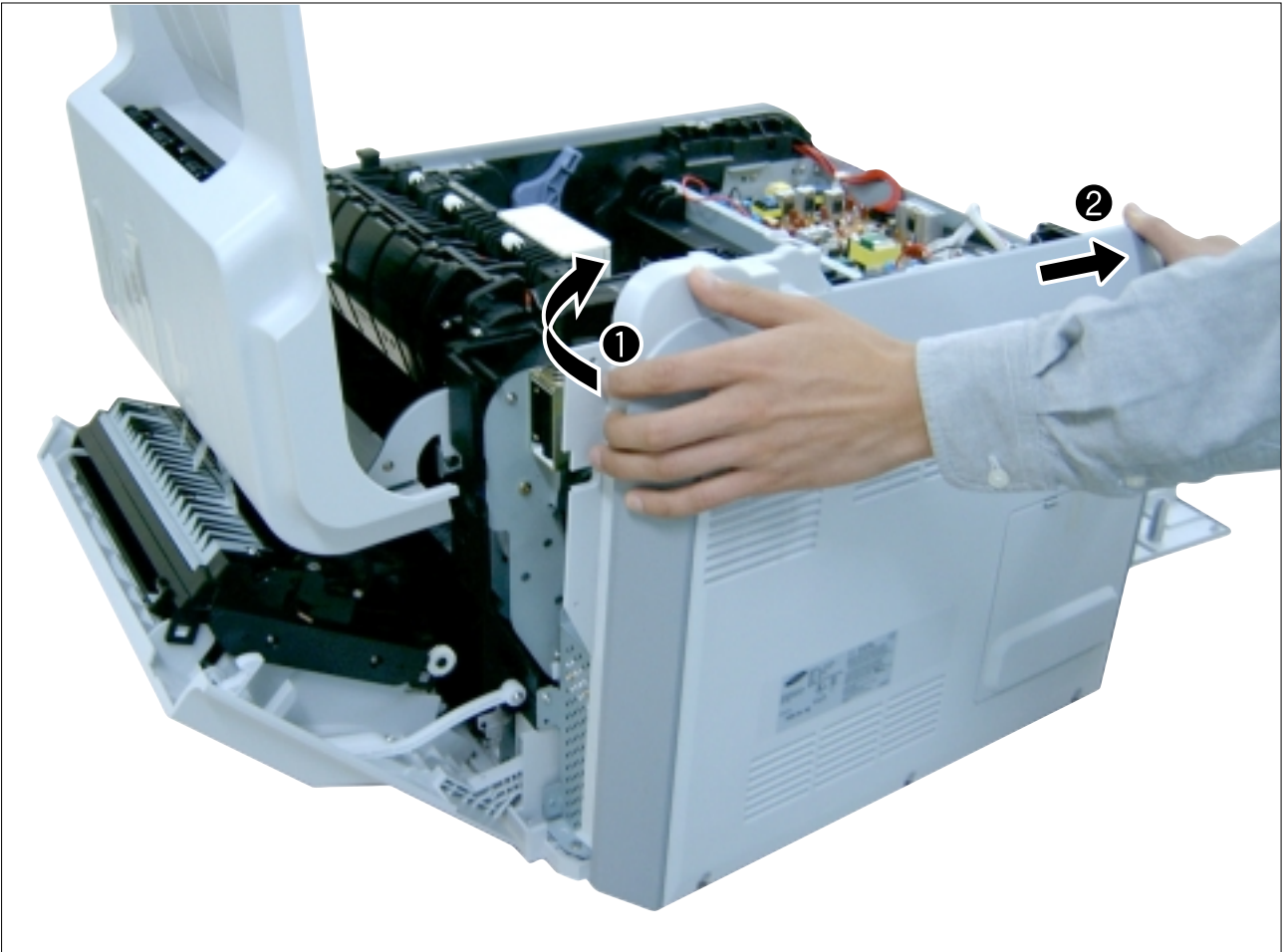

6.4.4 Duplex Cover Ass'y and Transfer Roller (T2)

>> Before disassembling it:

- * Open the duplex cover, the DEVE cover and the exit cover. (Refer to 6.3.3)
- * Remove the front cover and top cover. (Refer to 6.4.1)
- * Remove the rear cover. (Refer to 6.4.3)1)

1) Release 2 hinge screws (3*10 silver) - one on each side of the duplex unit.

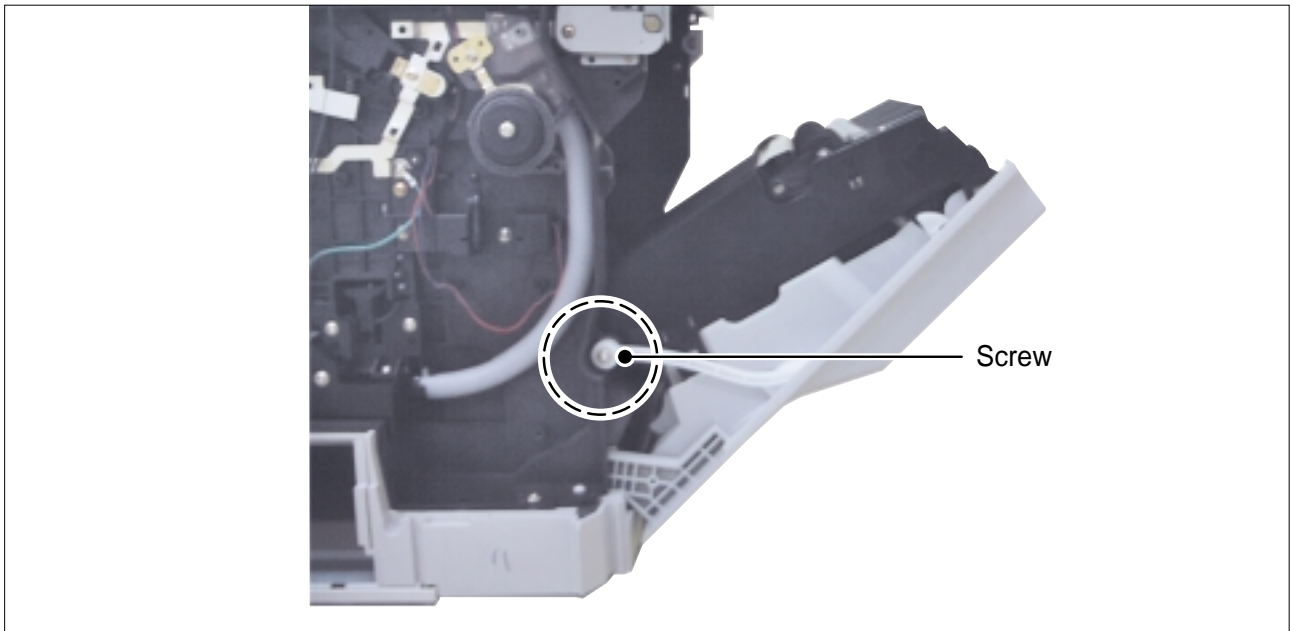

2) Remove the duplex cover ass'y by pulling it in the direction shown by the arrows in A and B below.

- * A: Lift up the left side section.
- * B: Remove the duplex cover ass'y by pulling the right side section towards the left.

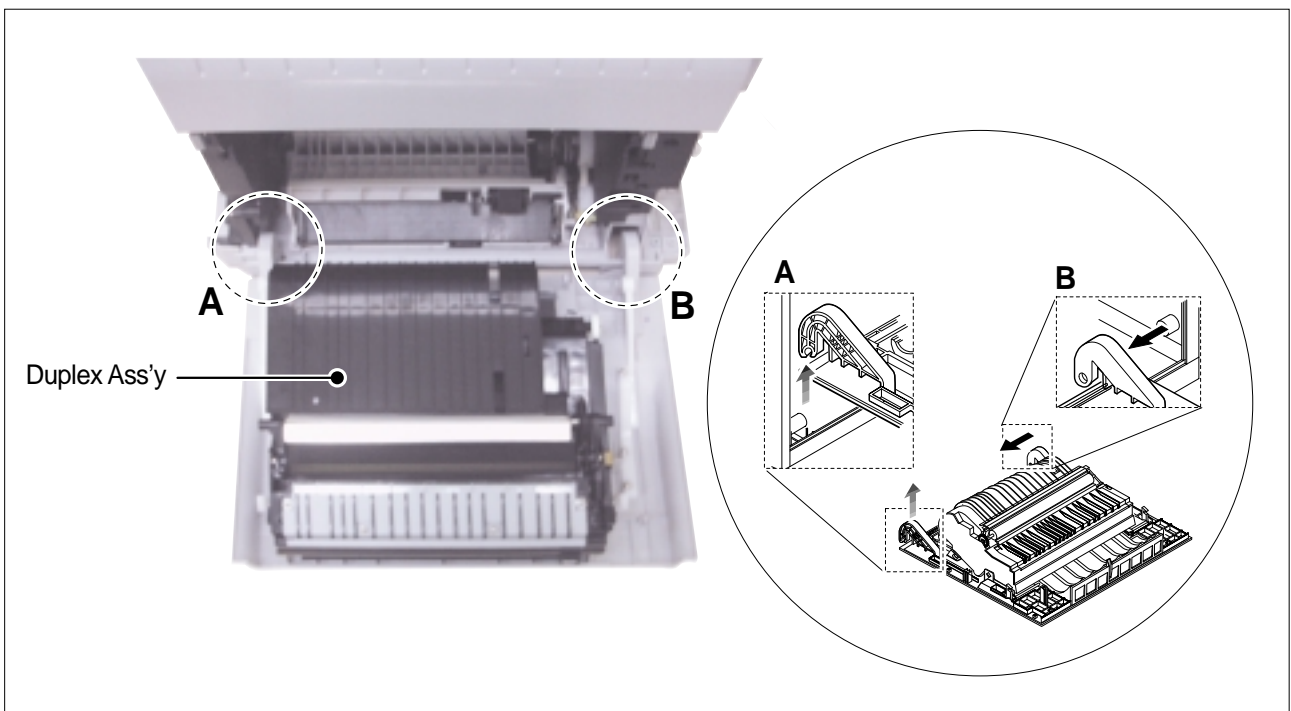

3) Release 4 hooks on the right and left side with a flat bladed screwdriver and then remove the duplex ass'y.

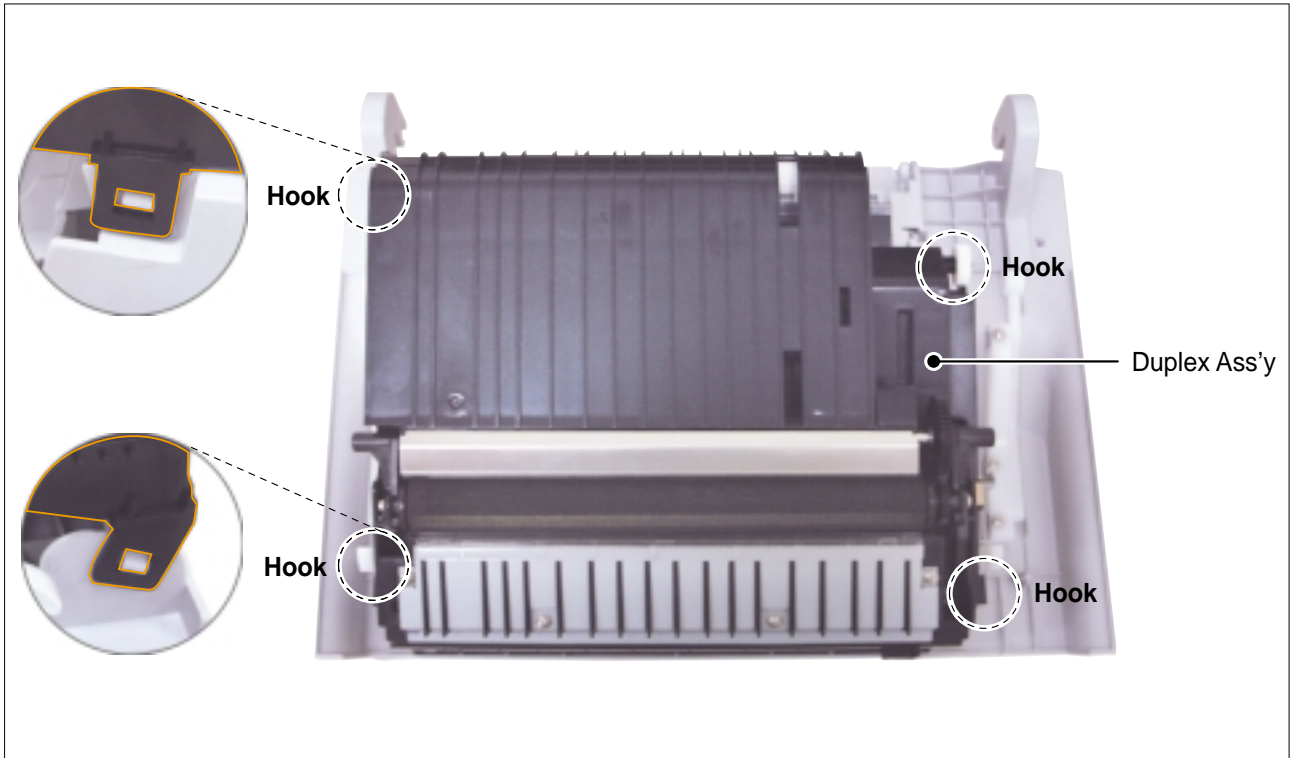

4) Remove the transfer roller by turning the bush on each end of the roller

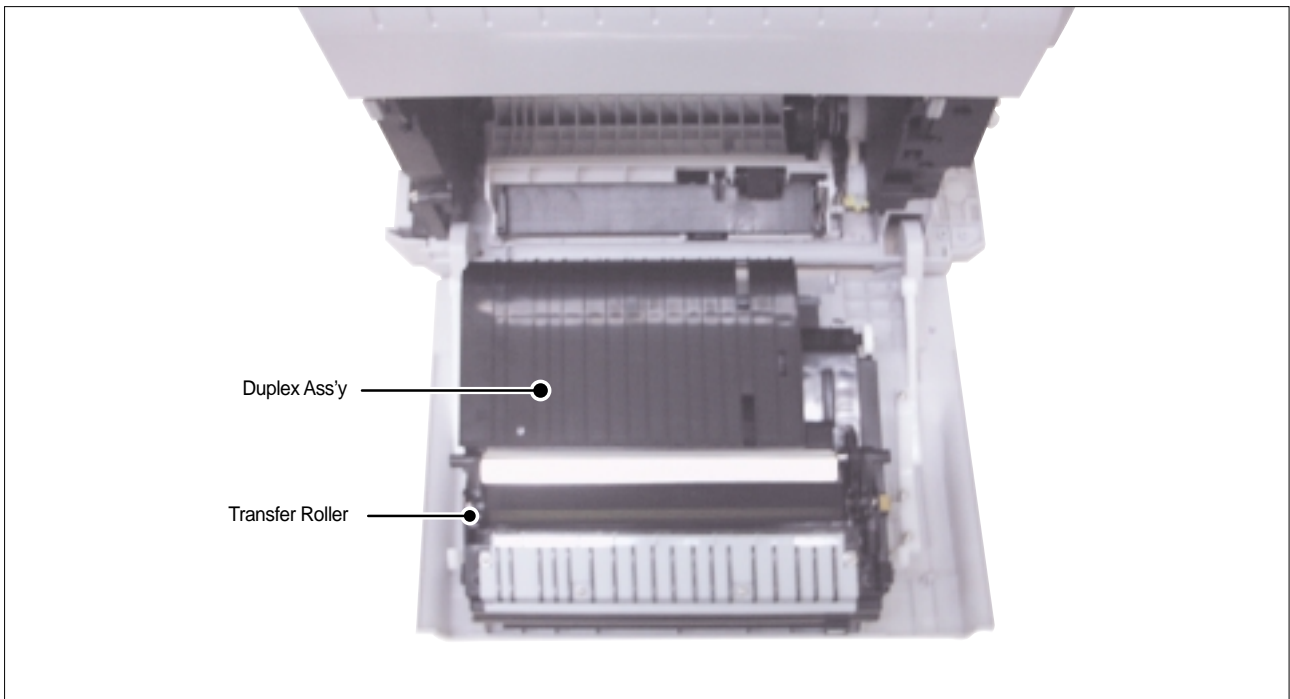

6.4.5 Fuser

1) Open the DEVE cover



Caution: Before opening the exit cover, completely open the DEVE cover until it is at right angles to the main frame and the toner cartridges are ejected

2) Open the exit cover.

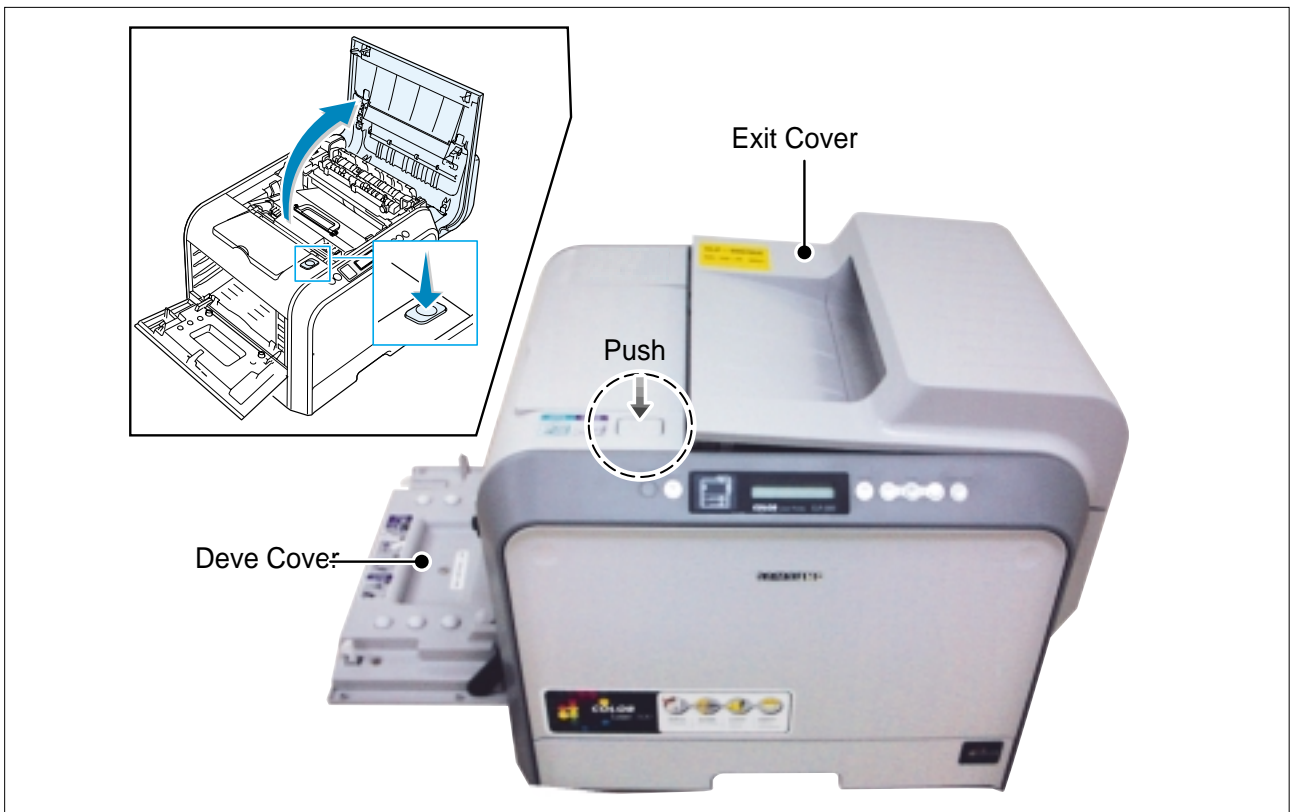

3) Release 5 screws (3*10 silver) and then remove the harness cover.

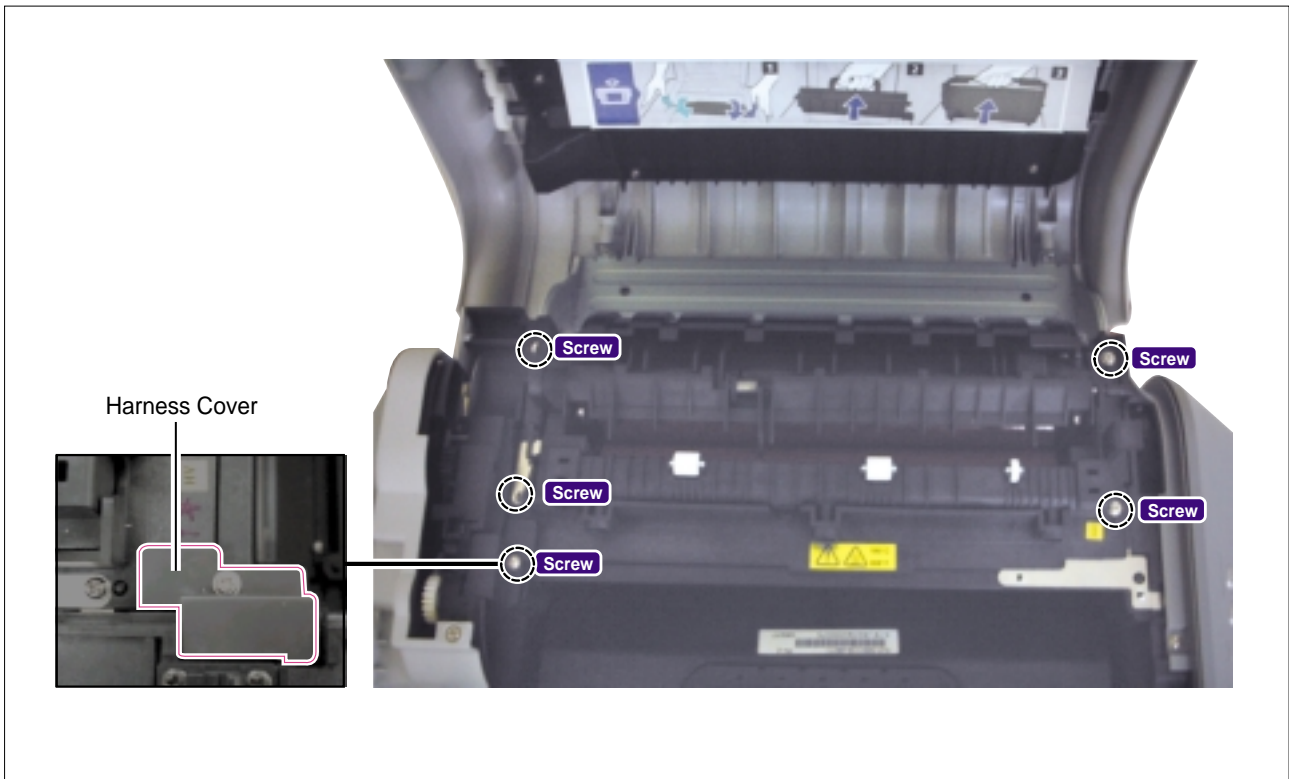

4) Remove one harness.

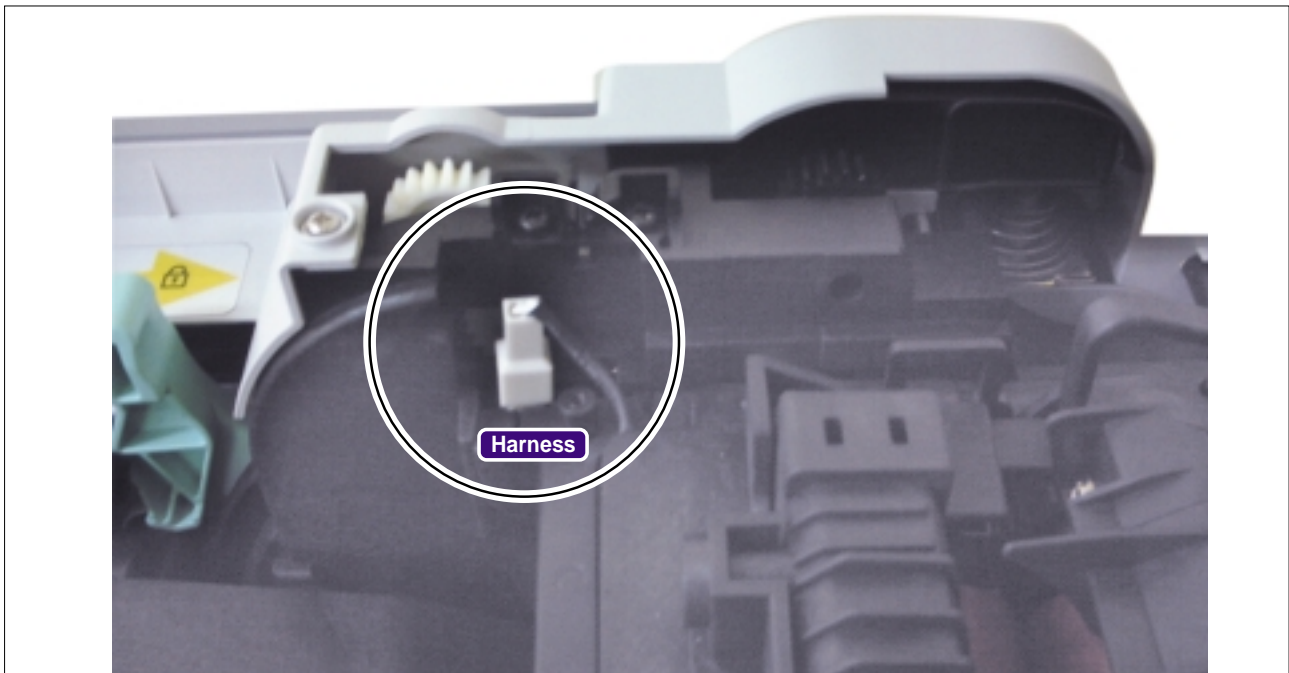

5) Remove the fuser by holding both sides of the fuser and then pulling the fuser upwards.

6.4.6 Exit Cover

>> Before disassembling it:

- * Remove the **front cover** (Refer to 6.4.1)
- * remove the **rear cover** (Refer to 6.4.3)
- * remove the **duplex cover** (Refer to 6.4.4.)

1) Remove the E-ring and the hinge pin by using a flat bladed screwdriver.

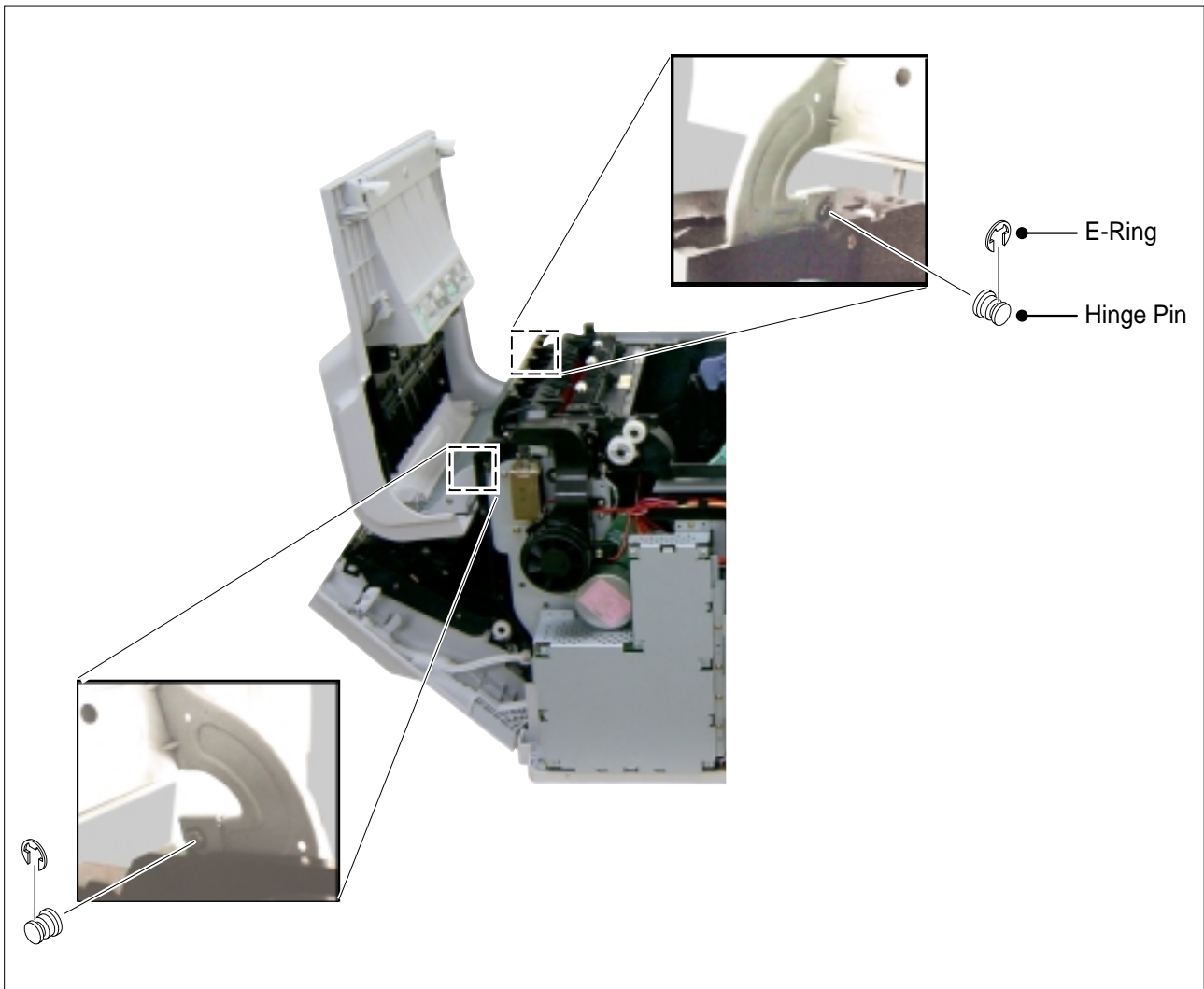

2) Remove the exit cover.

6.4.7 SMPS and Main PBA

>> Before disassembling it

*Remove the rear cover (Refer to 6.4.3)

1) Release 5 screws (3*6 machine screw, gold) from the main PBA bracket.

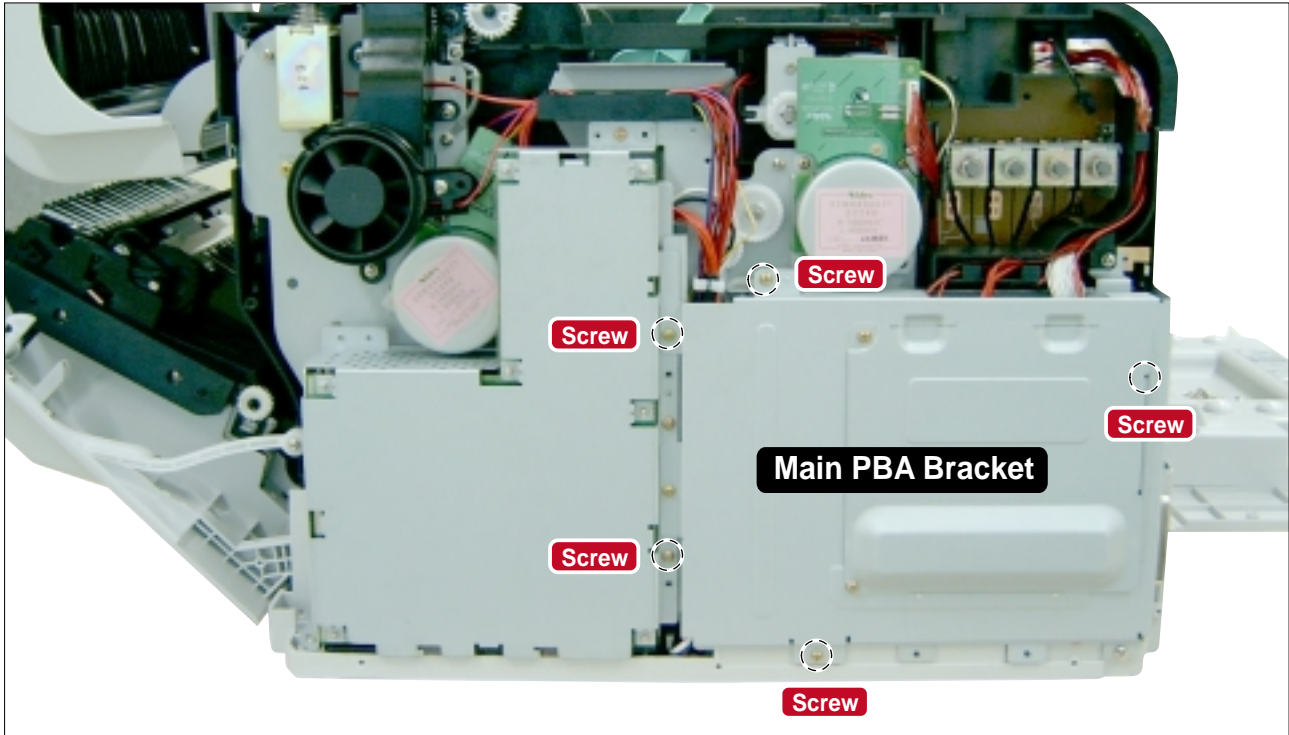

2) Release 2 screws (3*10 machine screw, silver) connected to the main PBA parallel port and then remove the main PBA bracket

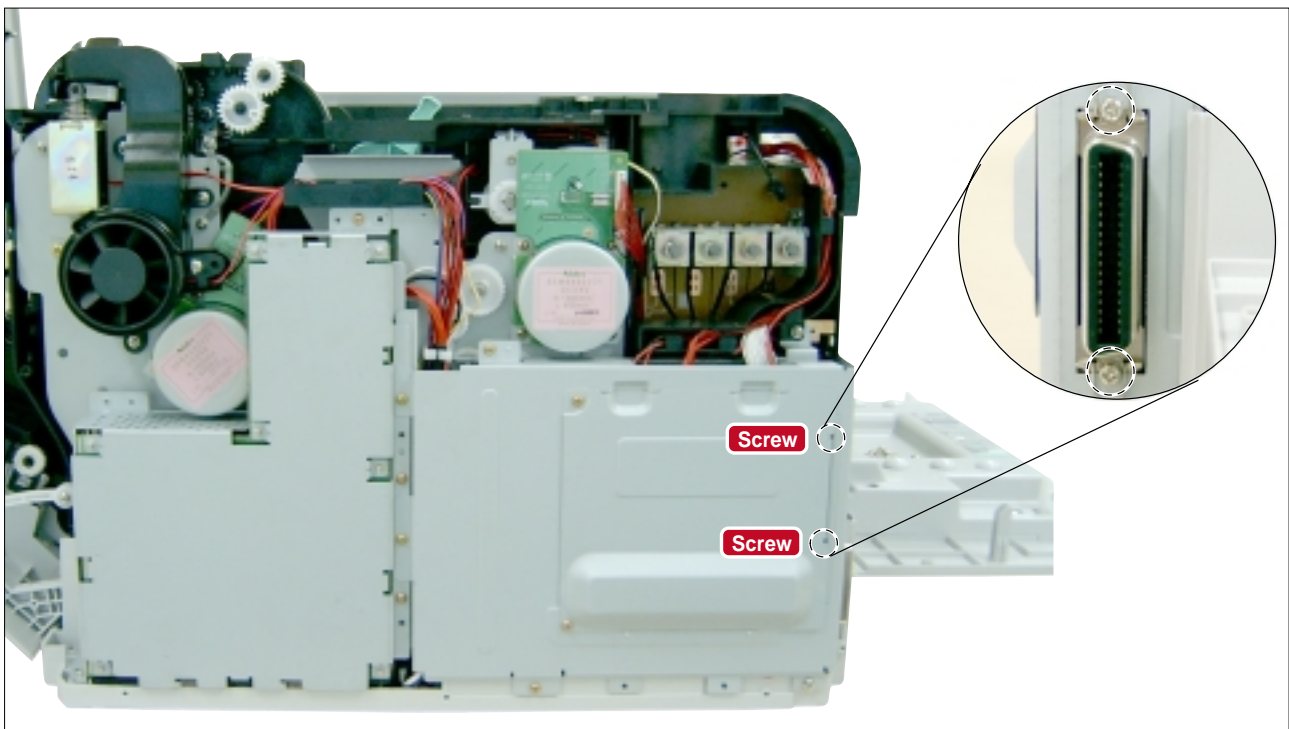

- 3) Release 5 screws from the SMPS.
 Release one screw (3*10 silver) from the harness guide.

- A: Right side 3EA (3 * 6 Gold)
- B: Left side 1EA (3 * 10 Silver)
- C: Bottom 1EA (4 * 10 Silver)

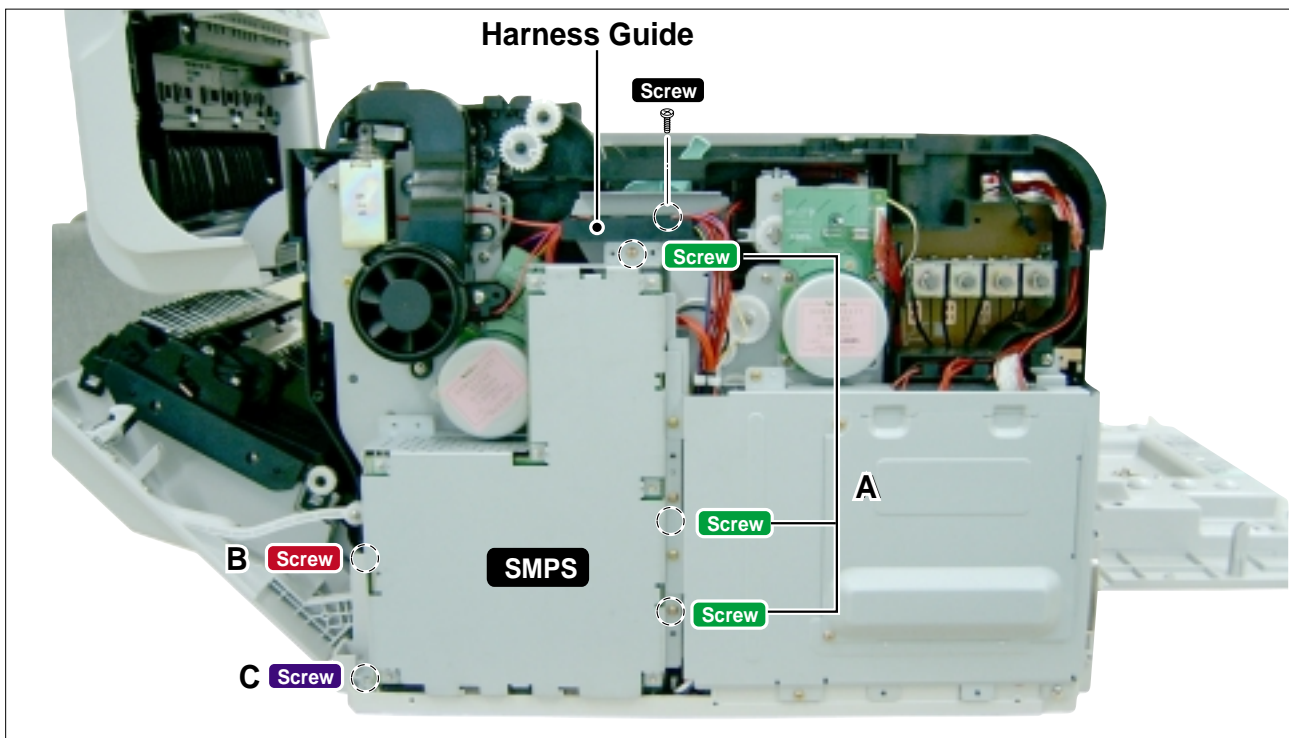

- 4) Remove 4 harnesses from the SMPS.

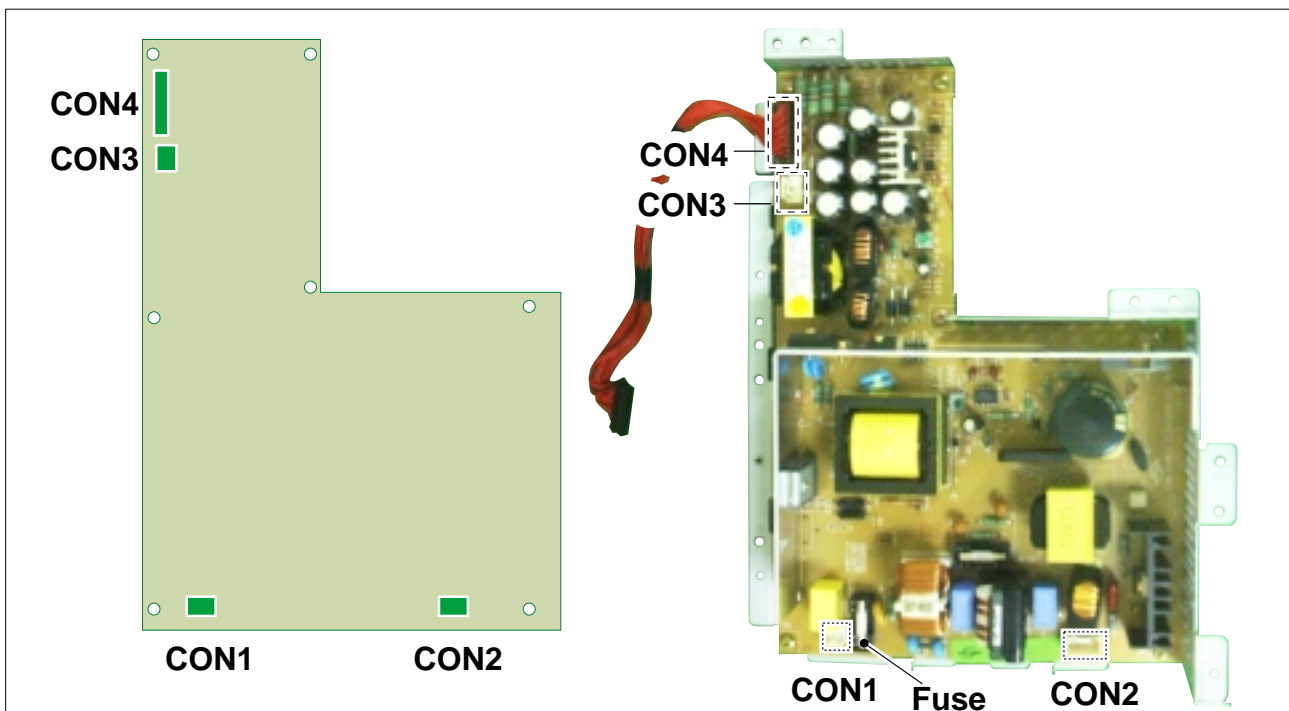

5) Remove all harness connected to the main PBA.

6) Release 5 screws (3*6 machine screw, gold) from the main PBA and then remove the main PBA.

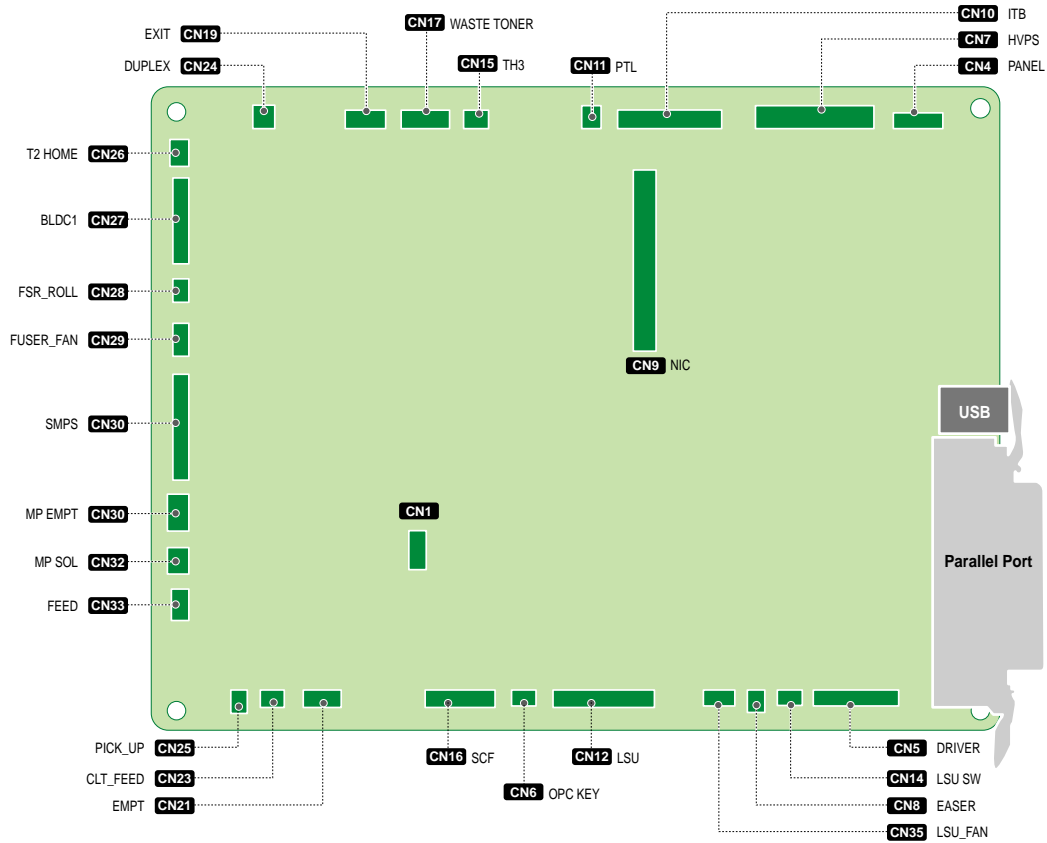
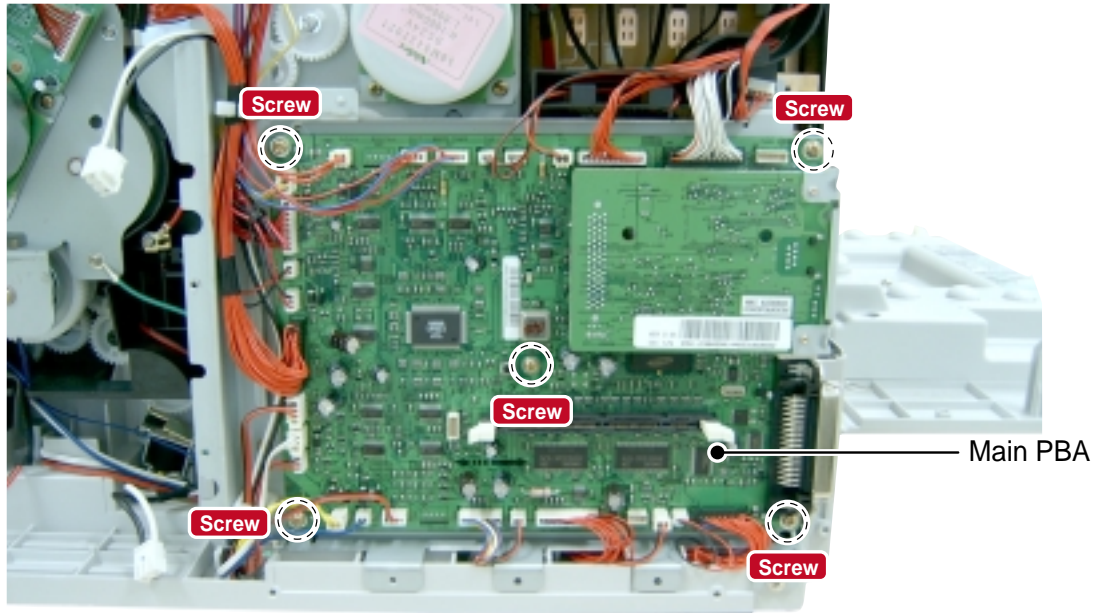

6.4.8 Fuser Fan

>> Before disassembling it:

- * Remove the **top cover** (Refer to 6.4.1)
- * Remove the **rear cover** (Refer to 6.4.3)
- * Remove the **main PBA bracket**. (Refer to 6.4.7)

1) Release 3 screws (3*10 silver) remove one harness from the main PBA and then take out the fuser fan.

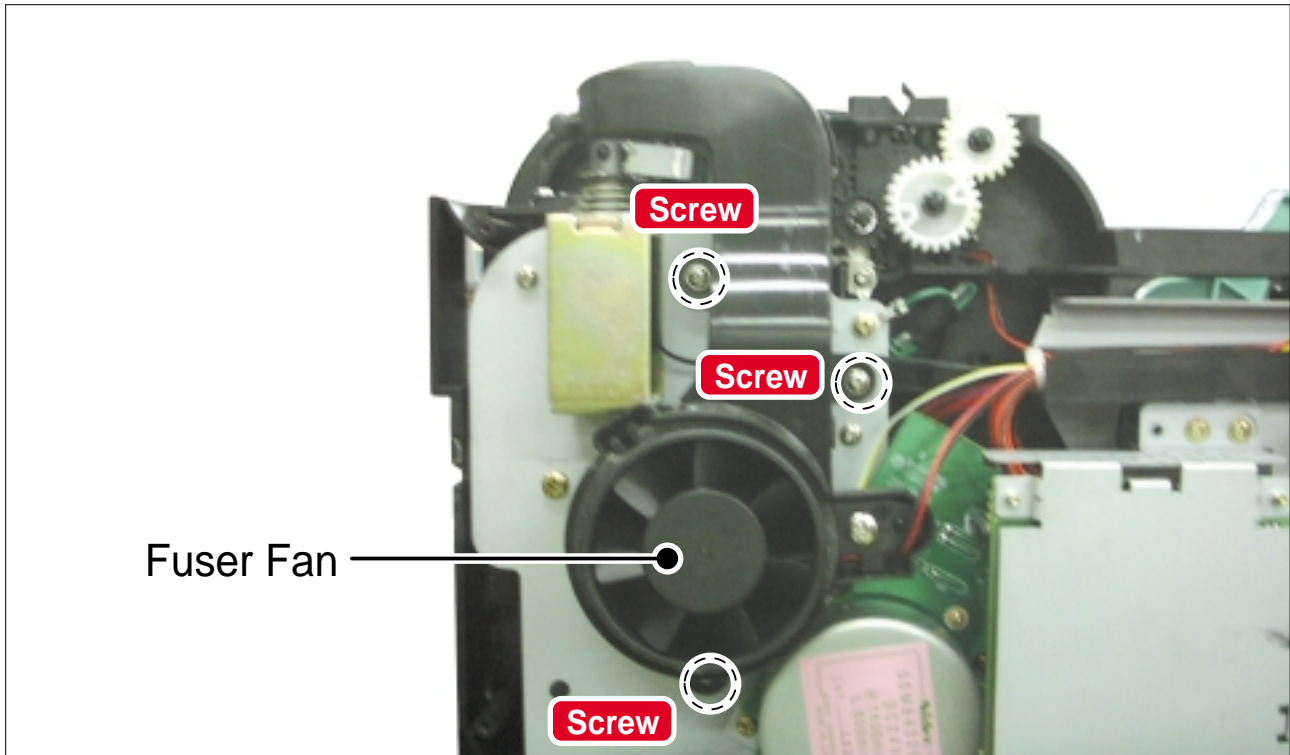

6.4.9 Main Drive Ass'y

>>Before disassembling it:

- * Remove the **rear cover** (Refer to 6.4.3)
- * Remove the **fuser** (Refer to 6.4.5)
- * Remove the **SMPS** (Refer to 6.4.7)
- * Remove the **fuser fan** (Refer to 6.4.8)

- 1) Remove all harnesses from the harness guides.
- 2) Remove the SMPS cover bracket.

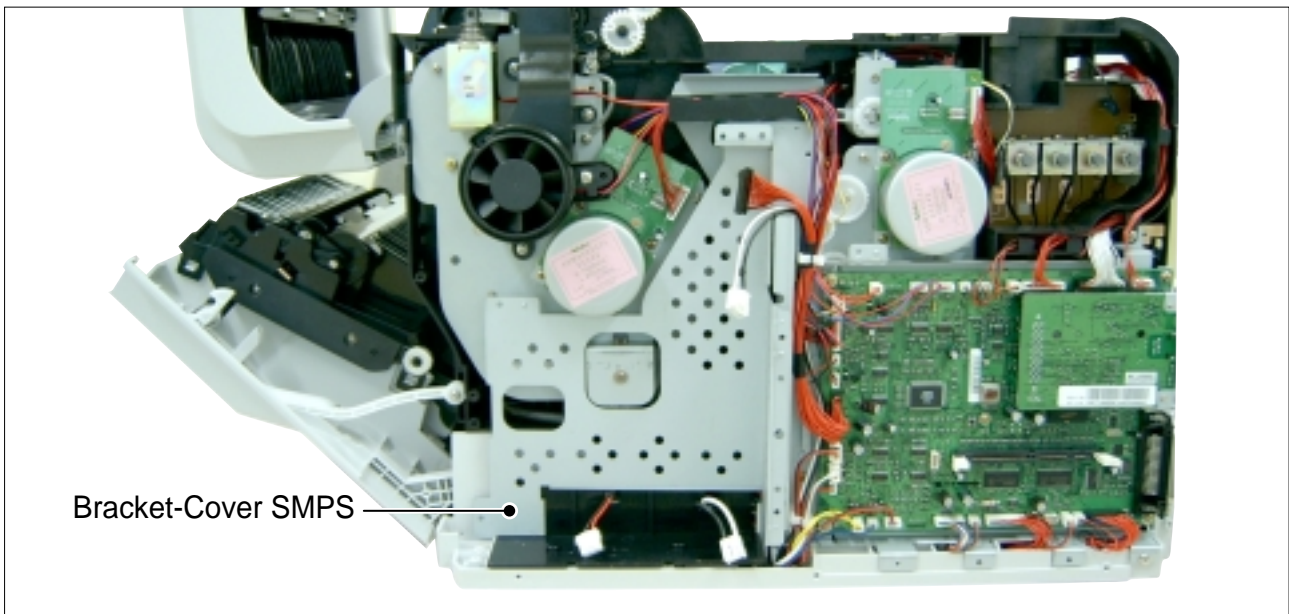

- 3) Look inside the OPC drum cavity and locate the T2 cam. Remove the washer using tweezers and then remove the T2 cam.

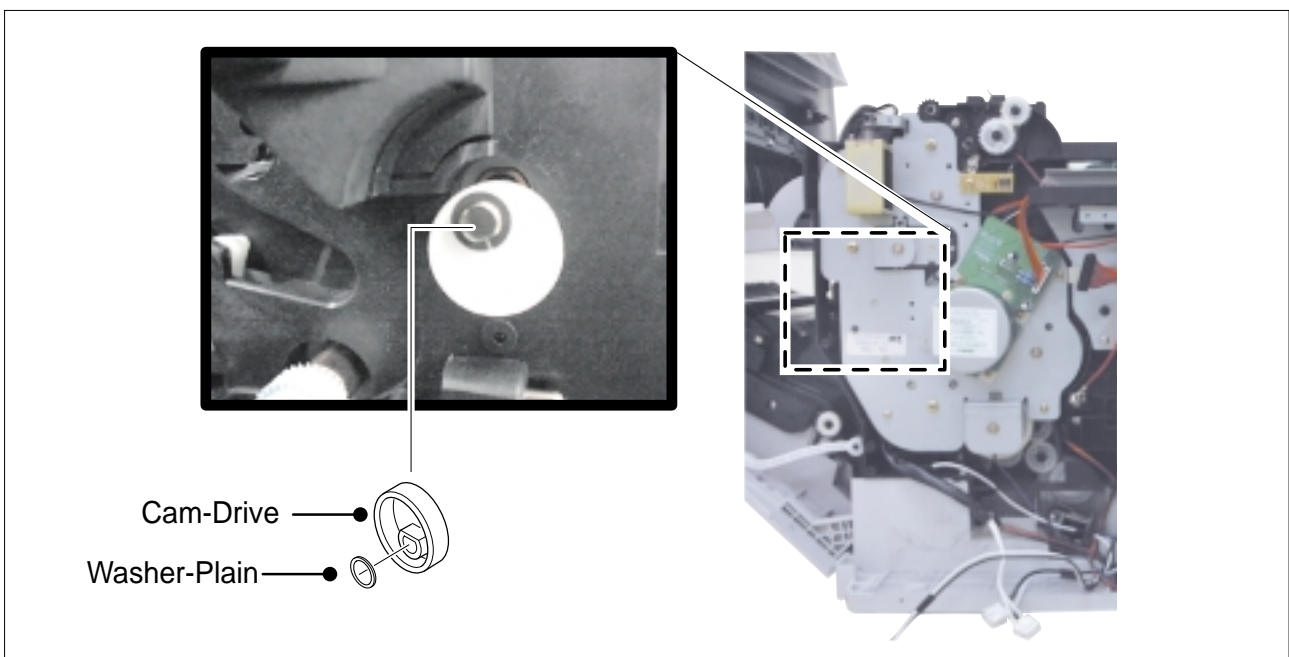

- 4) Remove the washer using tweezers and then remove the OPC gear and pin. (The OPC gear can be found inside the printer after removing the OPC drum unit. Take care that the pin is not lost as you remove the gear.)

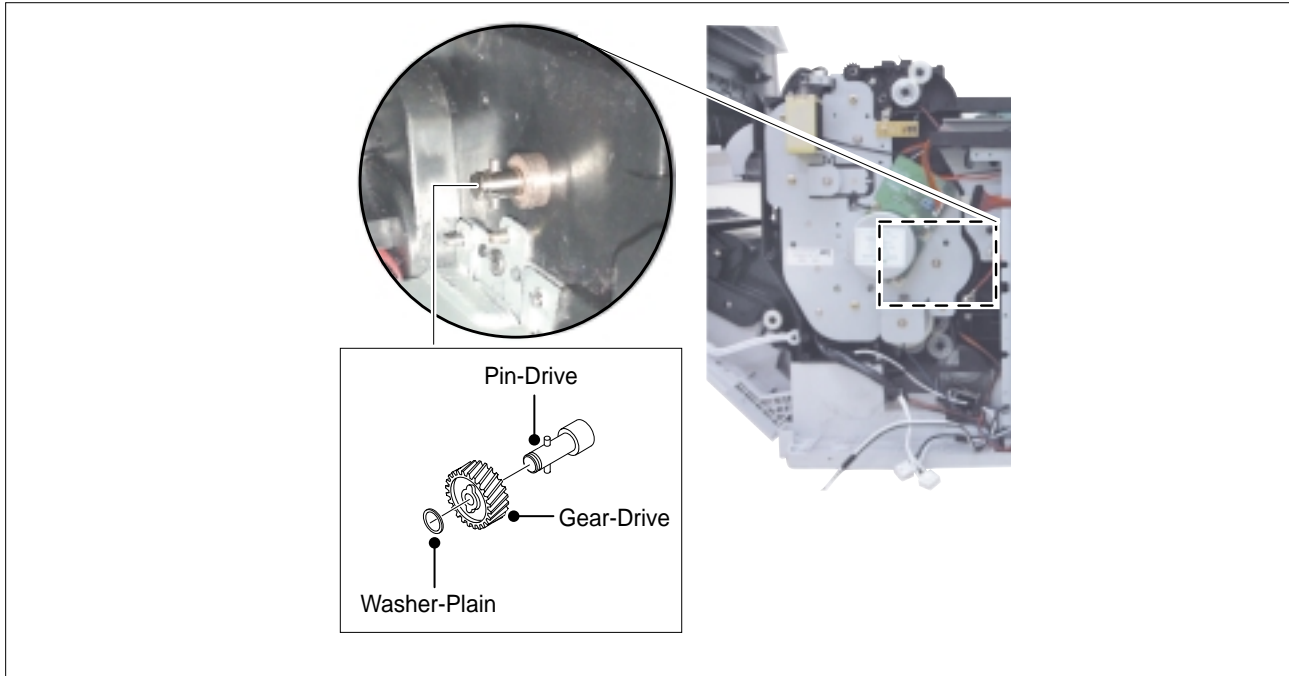

- 5) Remove the 3 harnesses Motor, Duplex solenoid and Feed Regi Clutch
Release 6 screws (3*10 silver) and then take out the main drive ass'y.

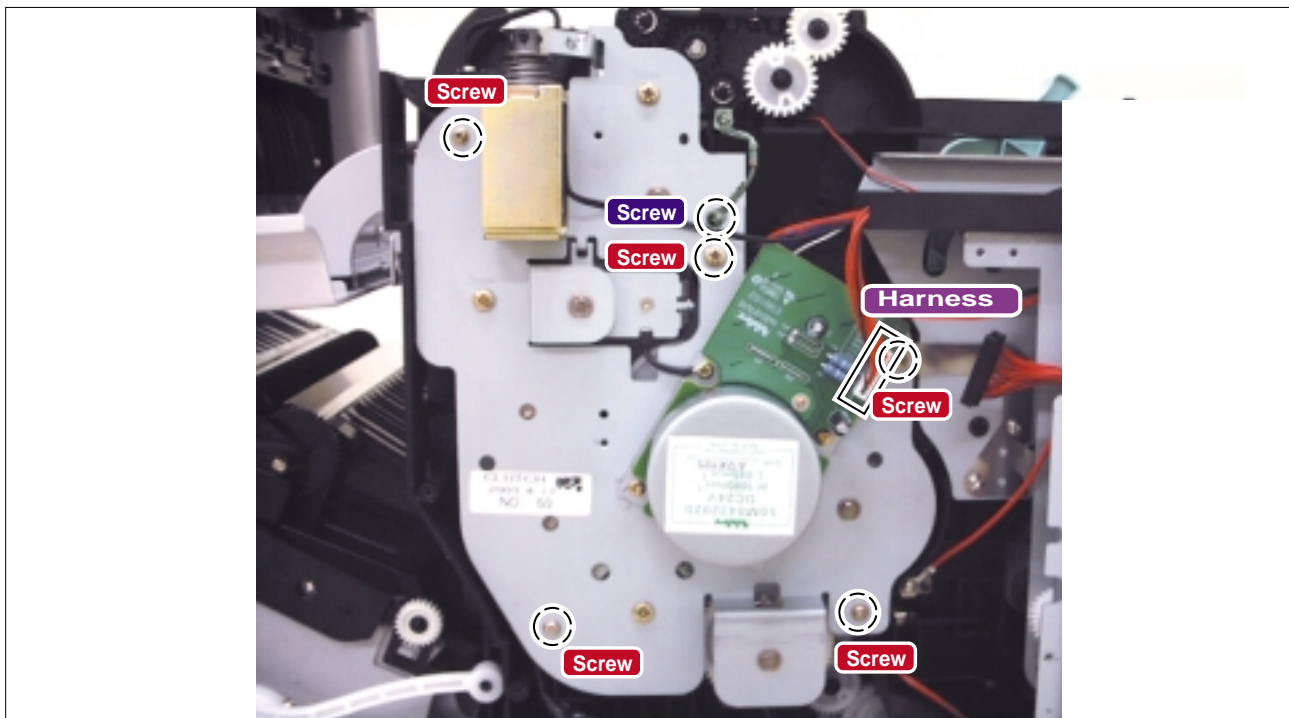

6.4.10 HVPS (High Voltage Power Supply)

>>Before disassembling it:

- * Disassemble the **front cover & top cover** (Refer to 6.4.1)
- * Disassemble the **rear cover** (Refer to 6.4.3)
- * Disassemble the **main PBA bracket** (Refer to 6.4.7.)

1) Remove one harness from the main PBA

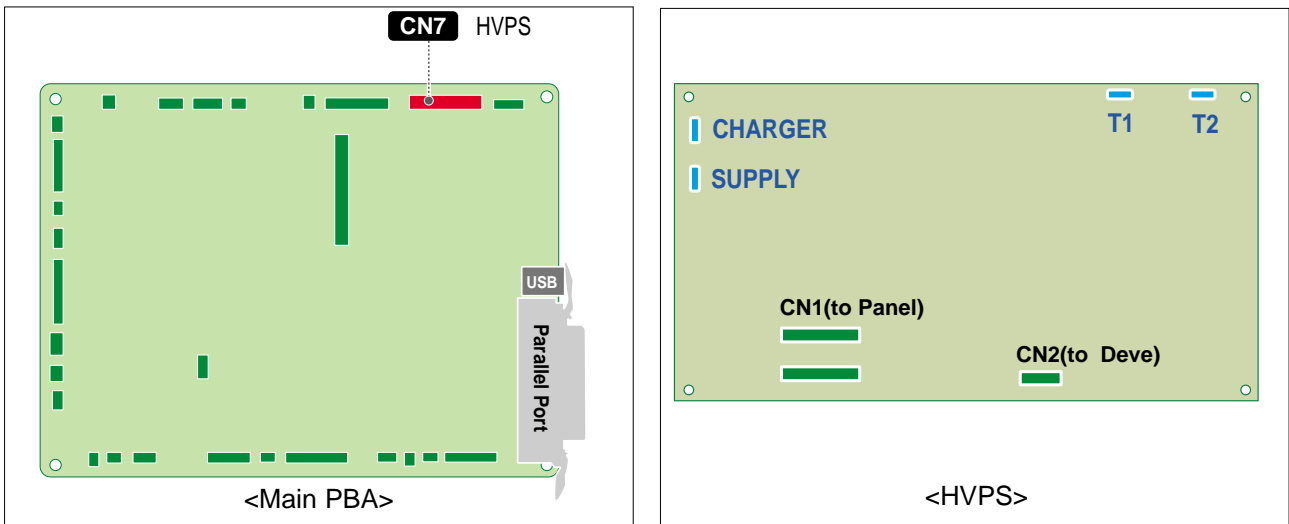

2) Remove one harness and 4 high-voltage harnesses from the HVPS.

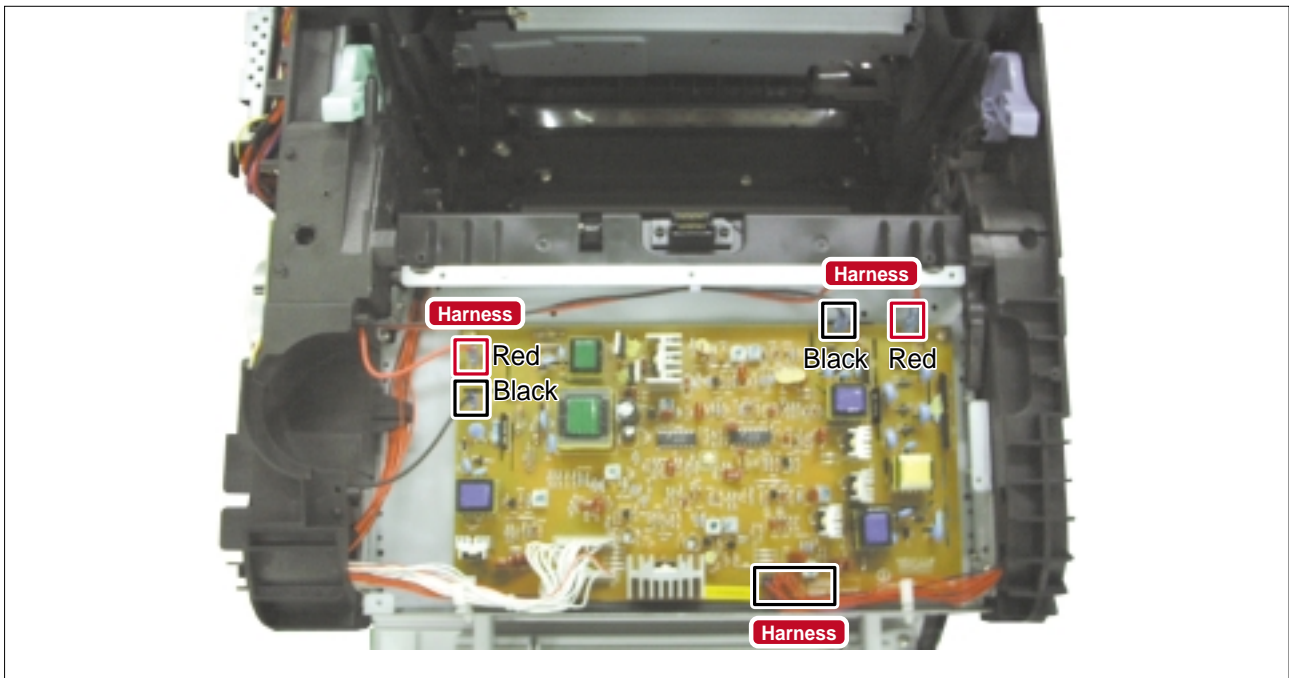

3) Remove 5 screws (3*6 machine screw, gold) and then remove the HVPS.

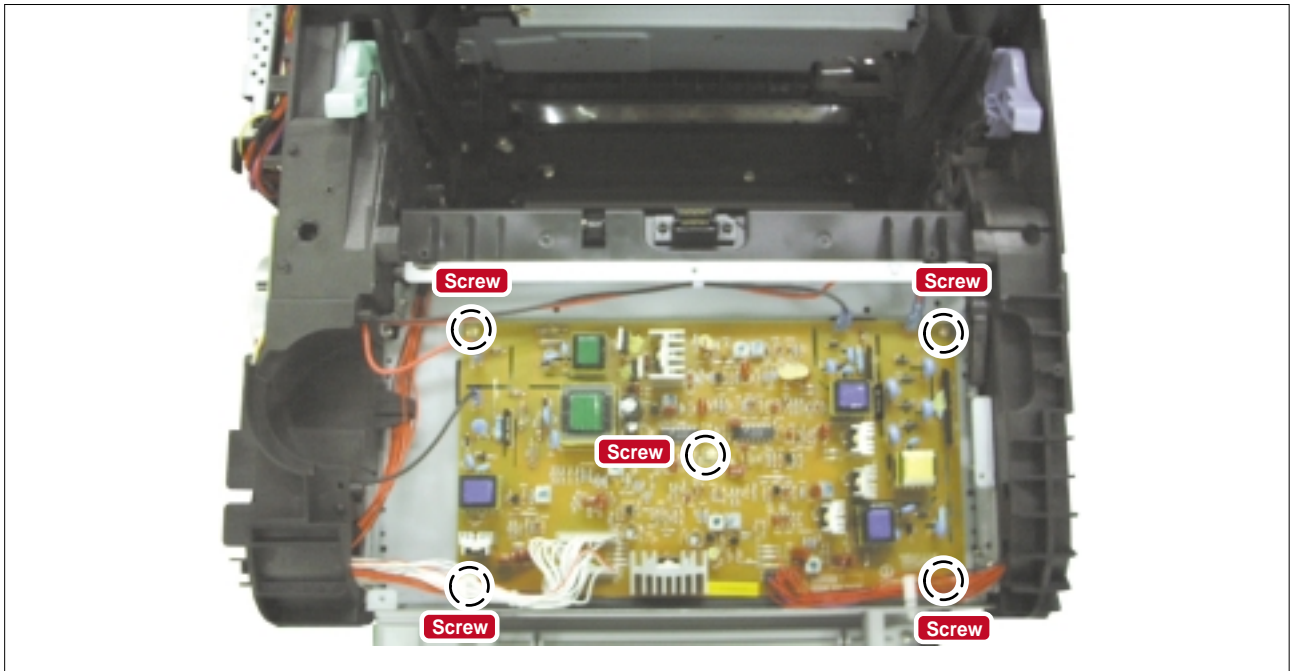

6.4.11 DEVE drive ass'y

>>Before disassembling it:

- * Disassemble the **rear cover** (Refer to 6.4.3)
- * Disassemble the **main PBA** (Refer to 6.4.7)

1) Remove the main PBA shield and harness guide by releasing 5 screws
 (2 EA 3*6 machine screw, gold; 2 EA 3*10 silver, 1 EA 4*10 silver)

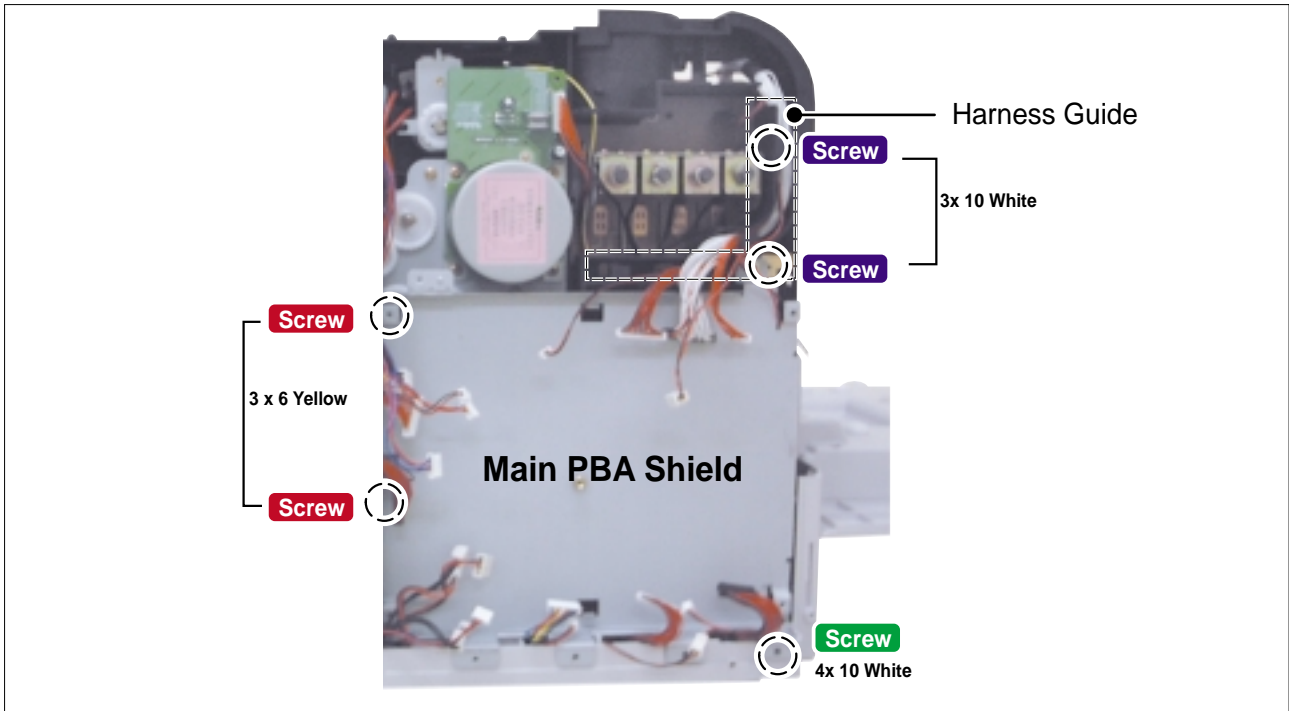

2) Remove the ground harness and the harness guide bracket by releasing 3 screws
 (2 EA 3*6 machine screw, gold: 1 EA 4*10 silver).

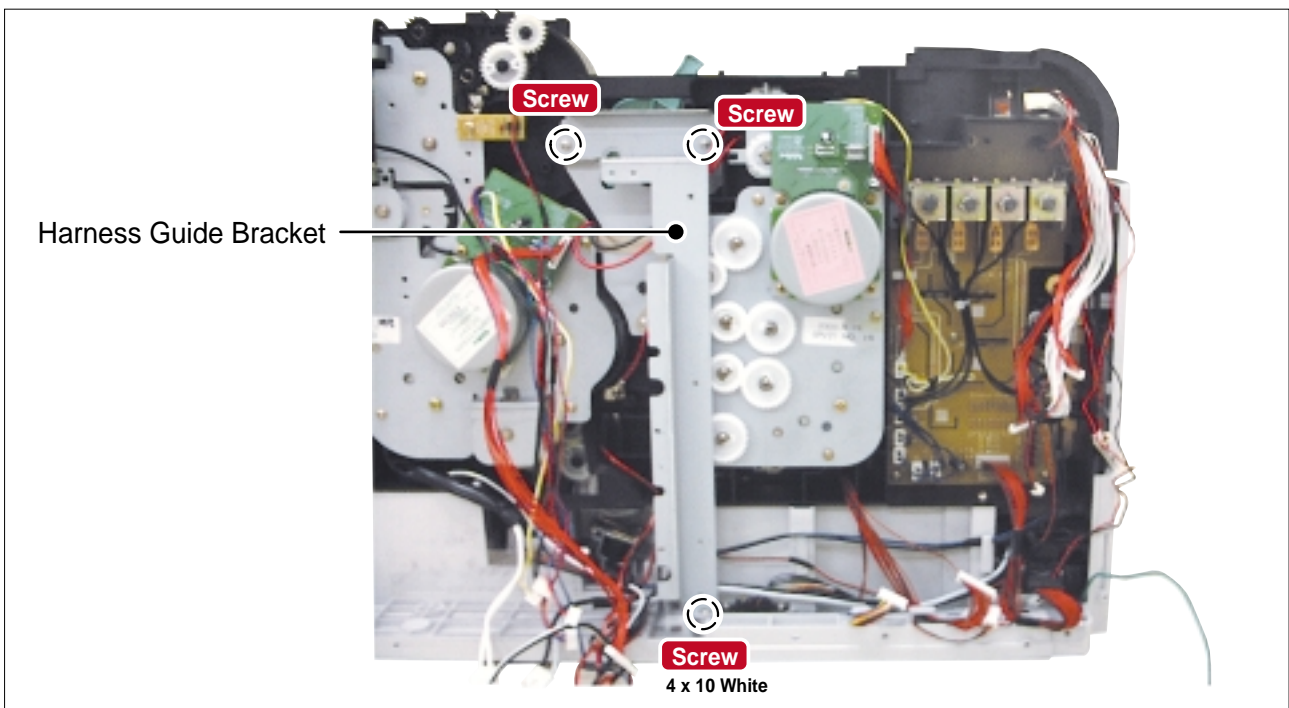

3) Separate the harness from the DEVE motor.

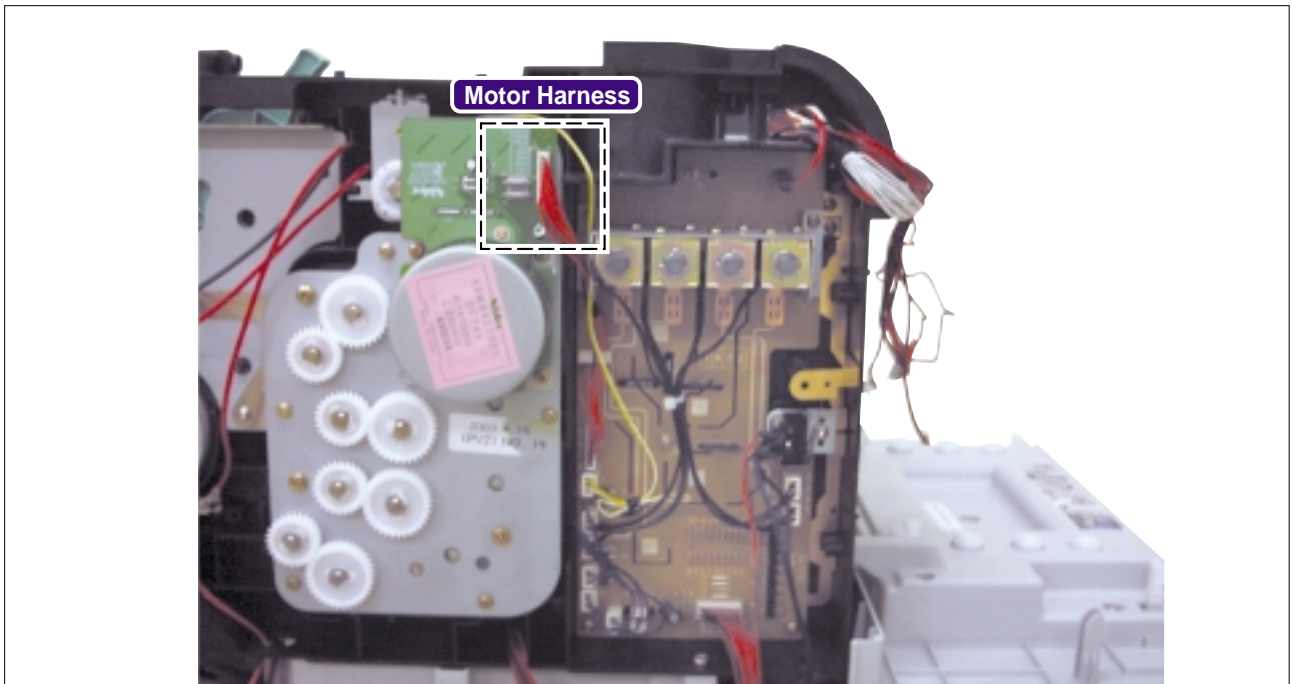

4) Release 5 screws (3*10 silver) from the DEVE drive ass'y.
 Remove 4 harnesses connected to the DEVE drive PBA and then remove the DEVE drive ass'y.

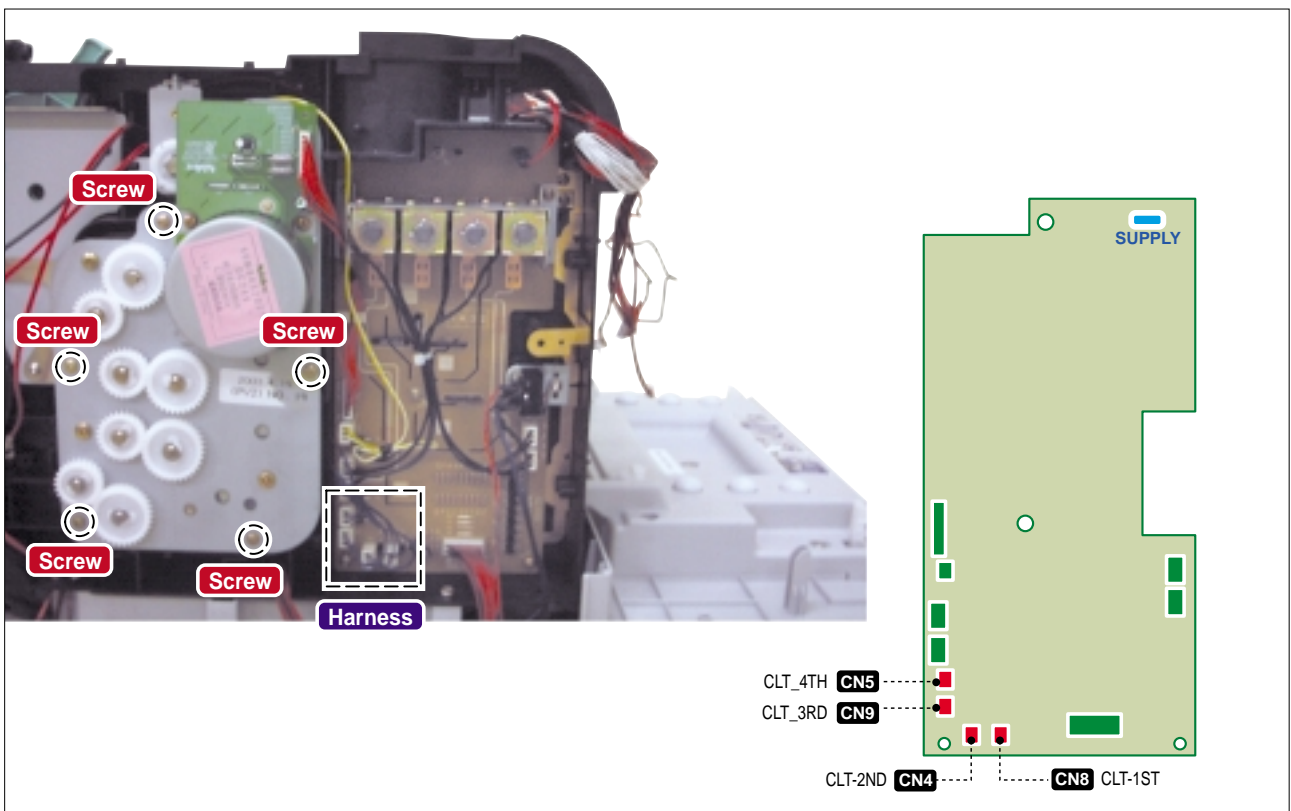

6.4.12 DEVE drive PBA and DEVE cover open S/W

>>Before disassembling it:

- * Disassemble the **rear cover** (Refer to 6.4.3)
- * Disassemble the **main PBA** (Refer to 6.4.7)
- * Disassemble the **main PBA bracket** (Refer to 6.4.7.2)

1) Release 1 screw (3*10 silver) and then take out the DEVE cover open S/W.

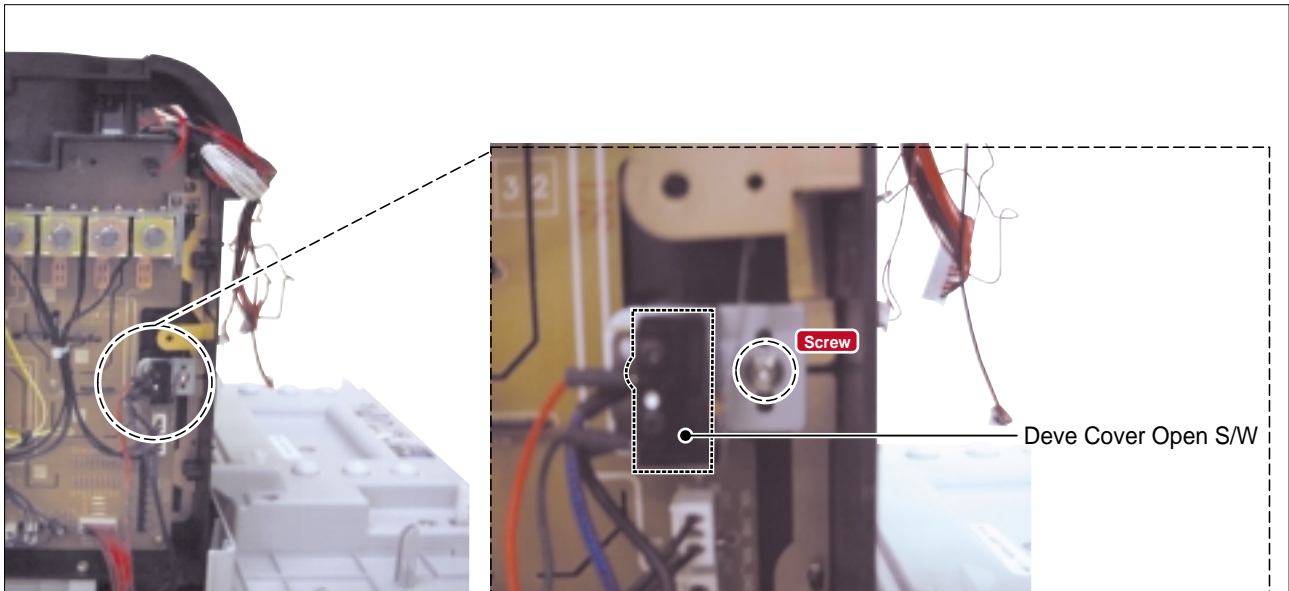

2) Remove all harnesses and 6 screws (3*10 silver) and then take out the DEVE drive PBA.

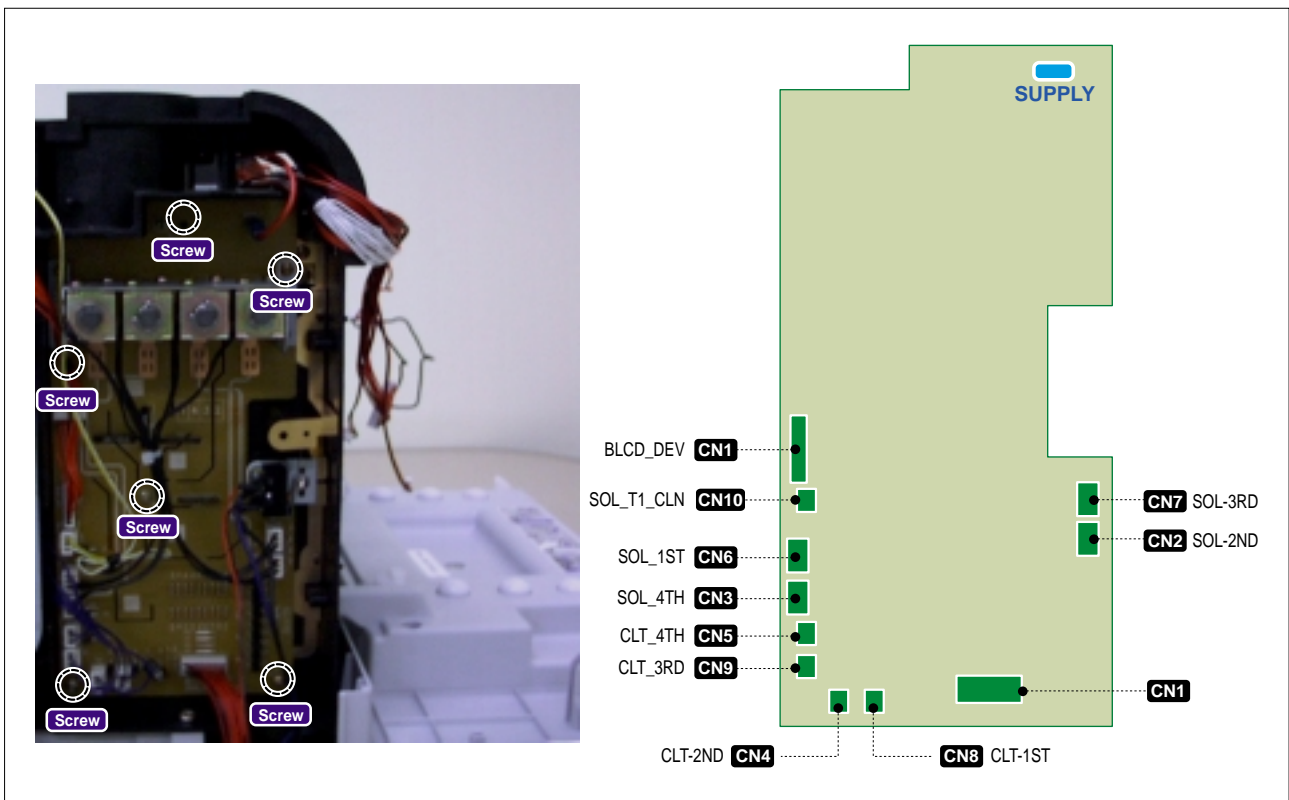

3) Remove 4 high-voltage terminals.

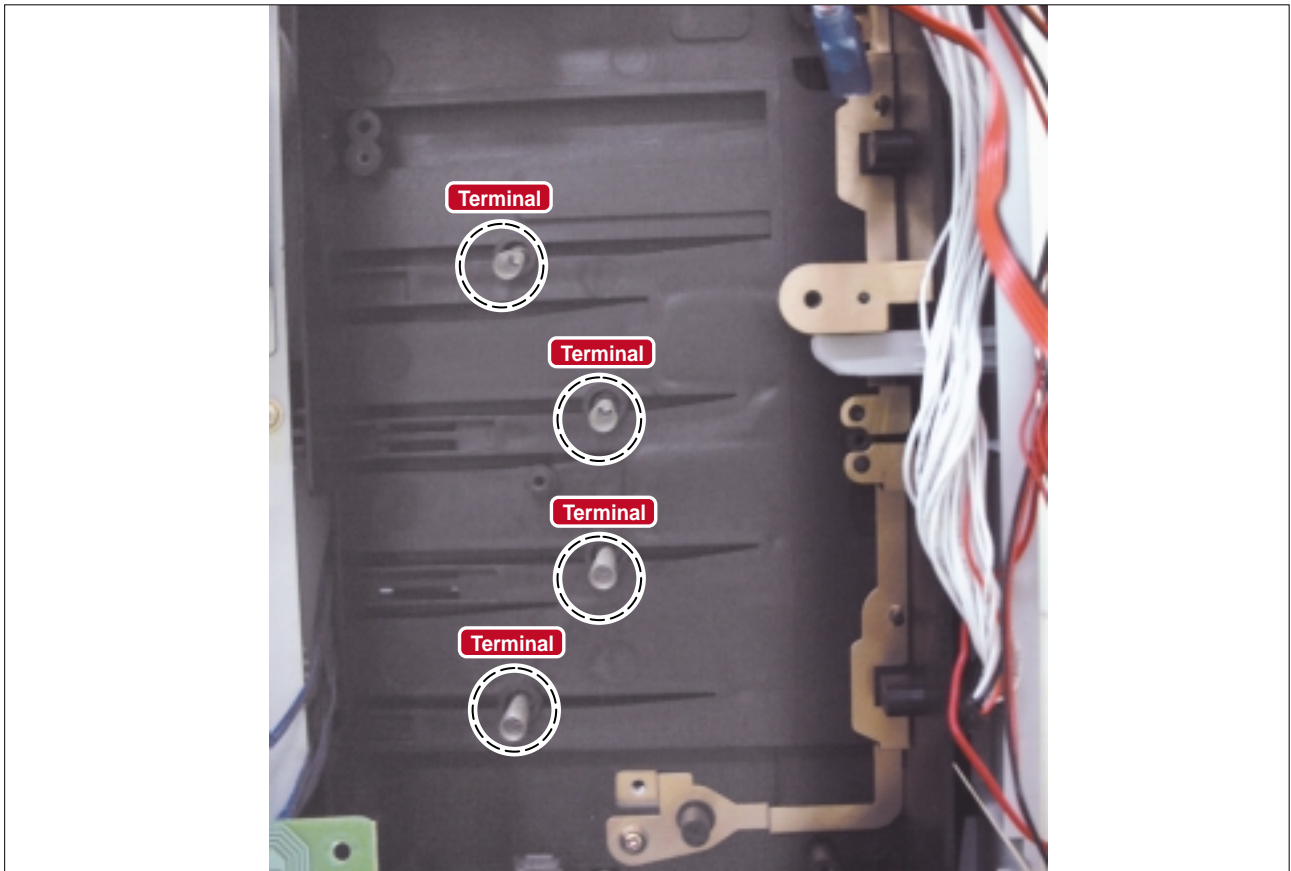

6.4.13 DEVE Drive Motor ITB Cleaning Solenoid

>>Before disassembling it:

- * Disassemble the **rear cover** (Refer to 6.4.3)
- * Disassemble the **main PBA** (Refer to 6.4.7)
- * Disassemble the **main PBA bracket** (Refer to 6.4.7)
- * Disassemble the **DEVE drive motor**. (Refer to 6.4.7)

1) Release 4 screws (3*6 gold) and then remove the DEVE drive motor.

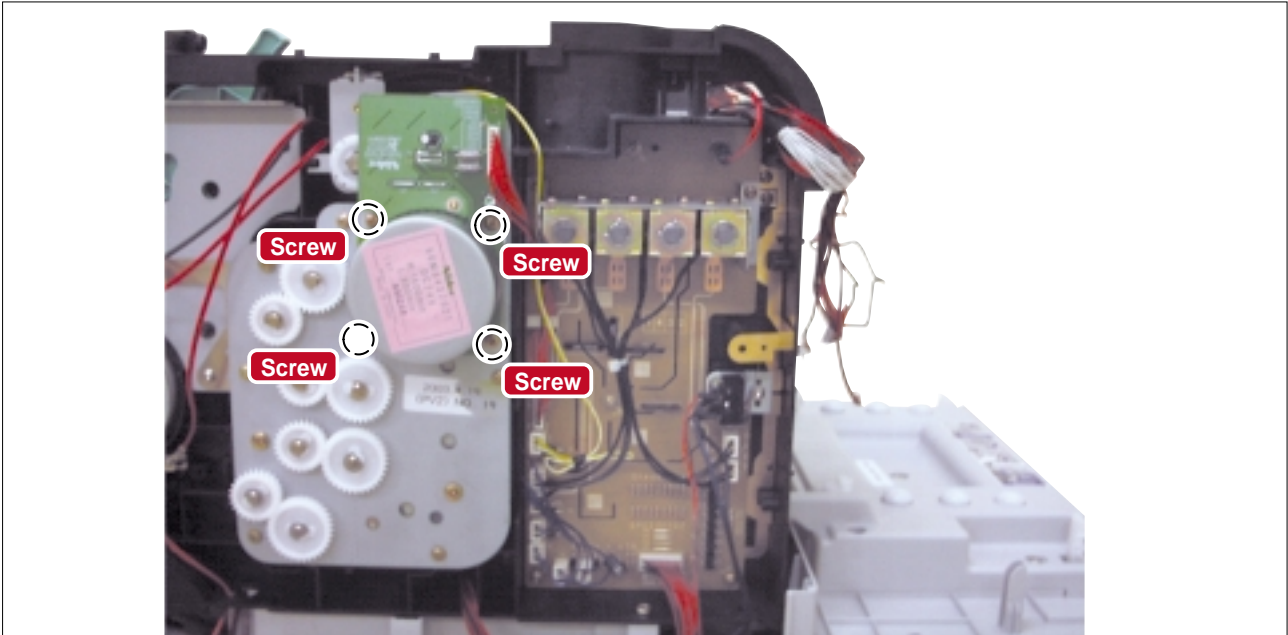

2) Unplug one harness from the DEVE drive PBA and then remove the ITB cleaning solenoid.

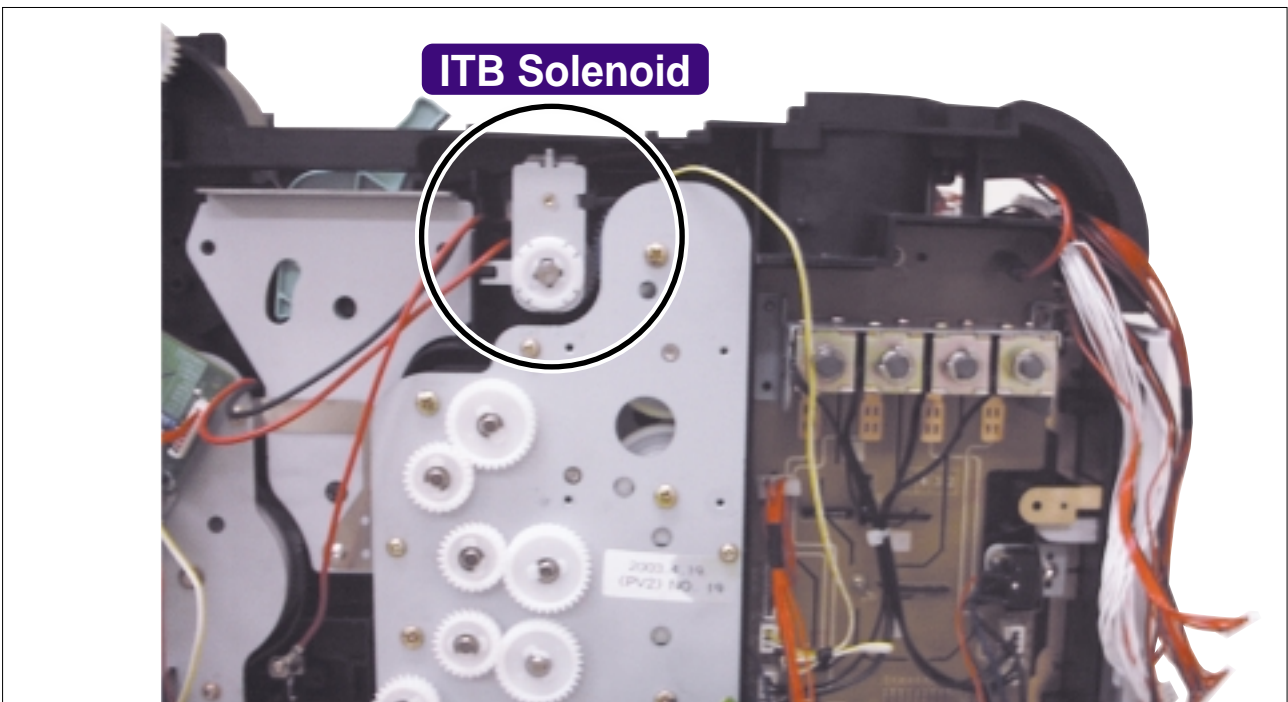

6.4.14 Erase Lamp

>> Before disassembling it:

- * Remove **all consumable parts** (Toner cartridge, ITB unit, and OPC drum) (Refer to 6.3.3)
- * Disassemble the **front cover and top cover** (Refer to 6.4.1)
- * Disassemble the **waster toner ass'y.** (Refer to 6.4.18)

- 1) Release 2 screws (4*15 gold) and 2 clips located close to the DEVE cover hinge and remove the LSU cover: A
Release one screw (4*10 silver) and then remove the lamp cover: B

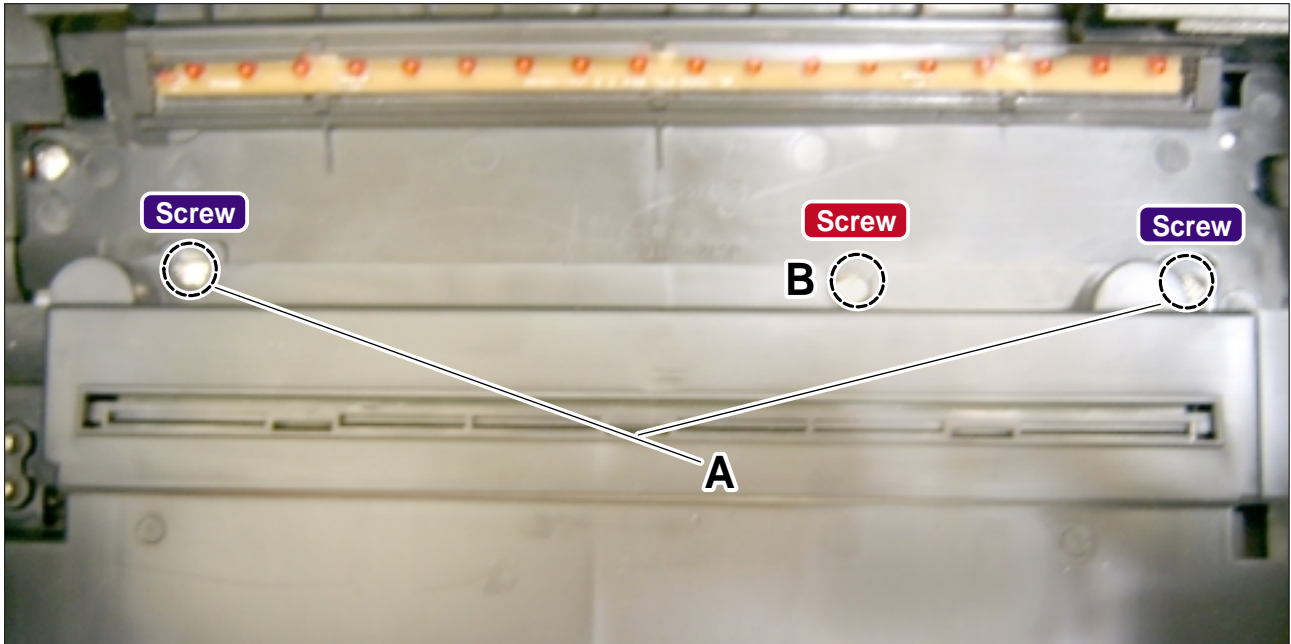

- 2) Release 2 clips and lift the eraser lamp ass'y, remove one harness and then remove the erase lamp.

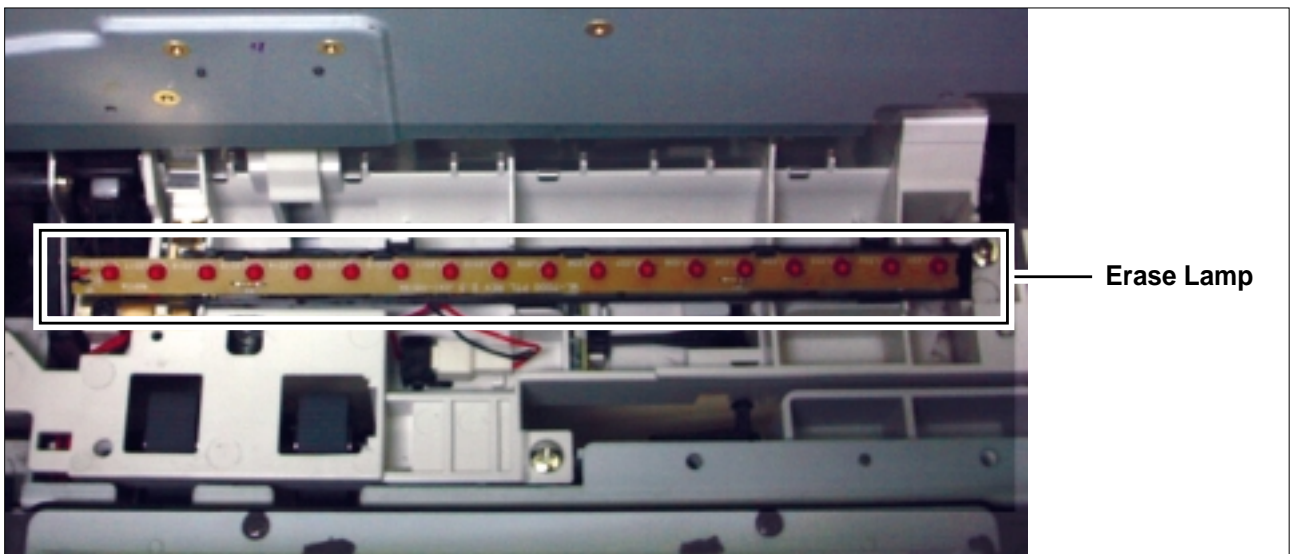

6.4.15 DEVE cover

>> Before disassembling it:

- * Remove **all consumable parts** (Toner cartridge, ITB unit, and OPC drum) (Refer to 6.3.3)
- * Disassemble the **front cover** and **top cover** (Refer to 6.4.1)
- * Disassemble the **LSU cover**. (Refer to 6.4.14)

1) Remove 2 screws (3*10 silver) and then remove the DEVE open link guide.

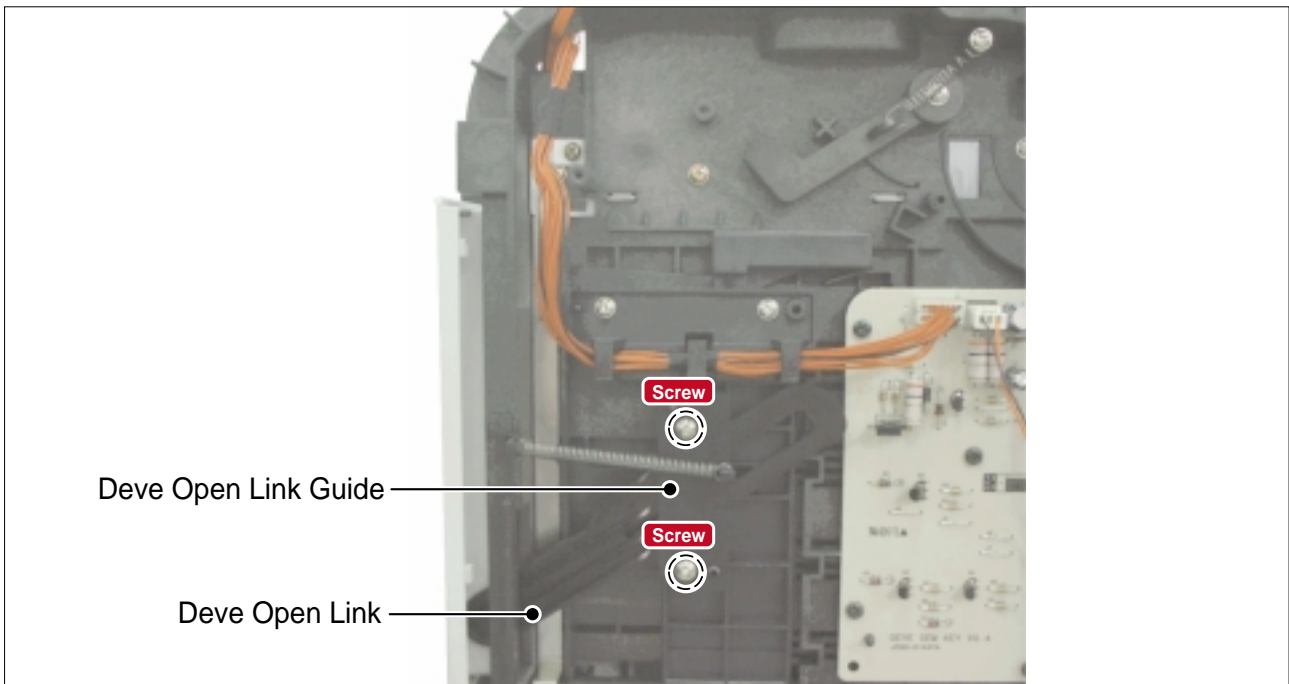

2) Separate the DEVE cover by pulling it in the direction of the arrow.

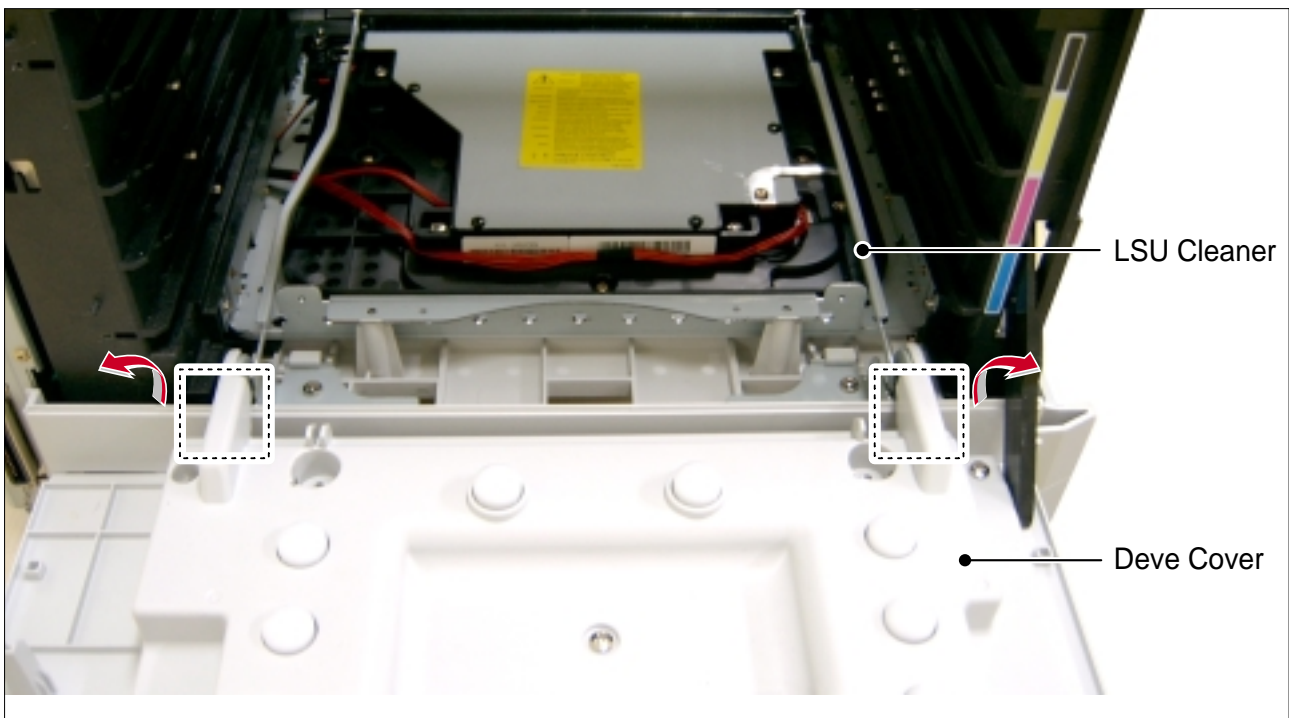

6.4.16 LSU unit

>> Before disassembling it:

- * Remove the consumable parts (Toner cartridge, ITB unit, and OPC drum) (Refer to 6.3.3)
- * Disassemble the **Deve cover**. (Refer to 6.4.15)

1) Release 4 screws (4*10 silver). (Use a short length cross-head screwdriver.)

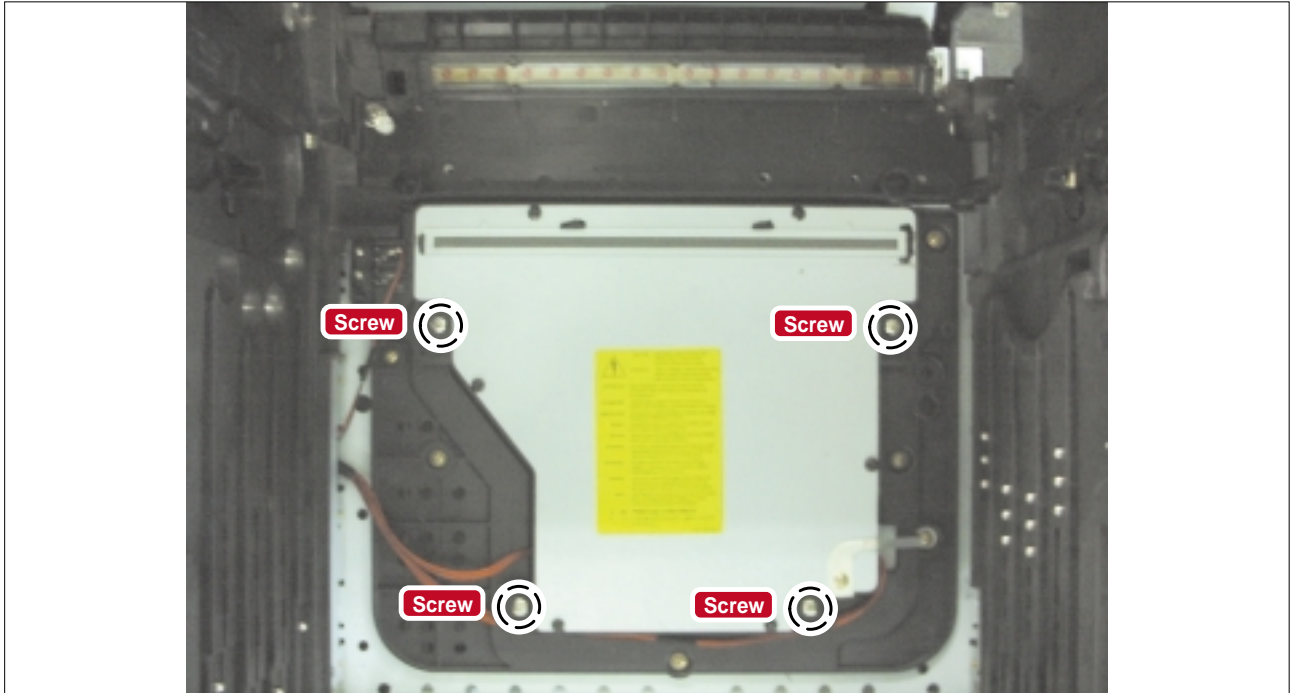

2) Release one screw (3*8 yellow). (Use a short length cross-head screwdriver.)

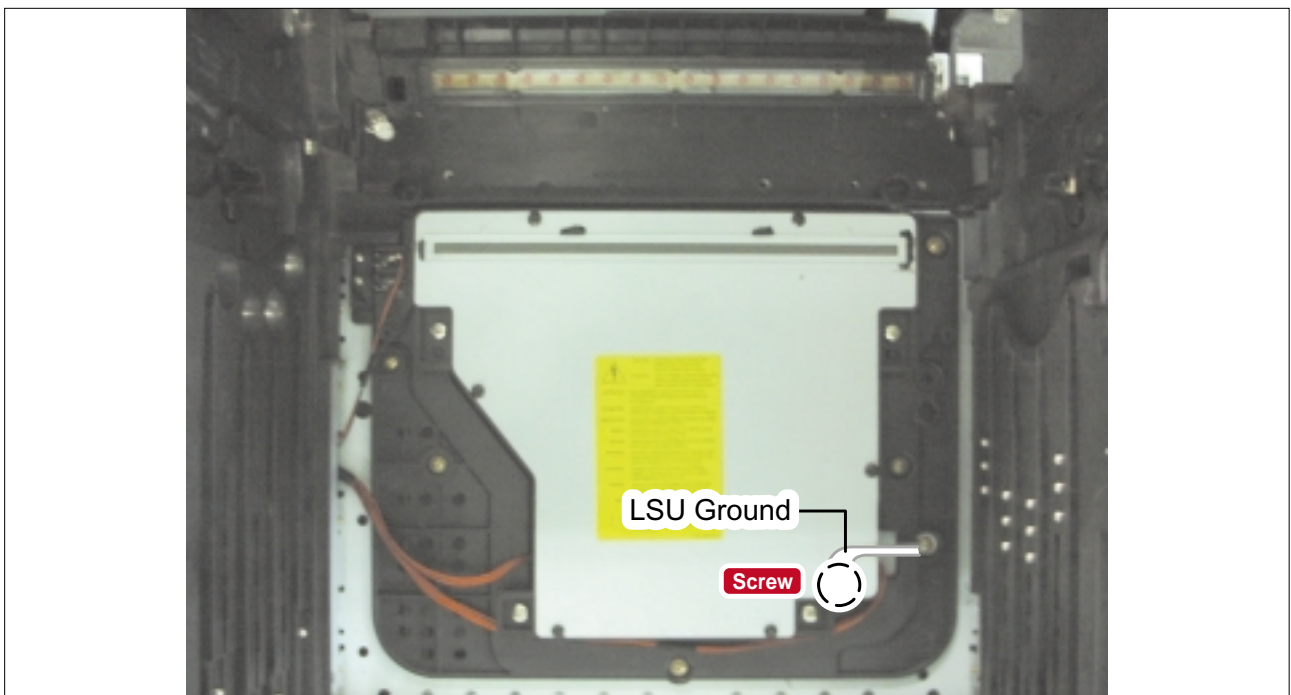

3) Separate 2 harnesses and remove the LSU unit.

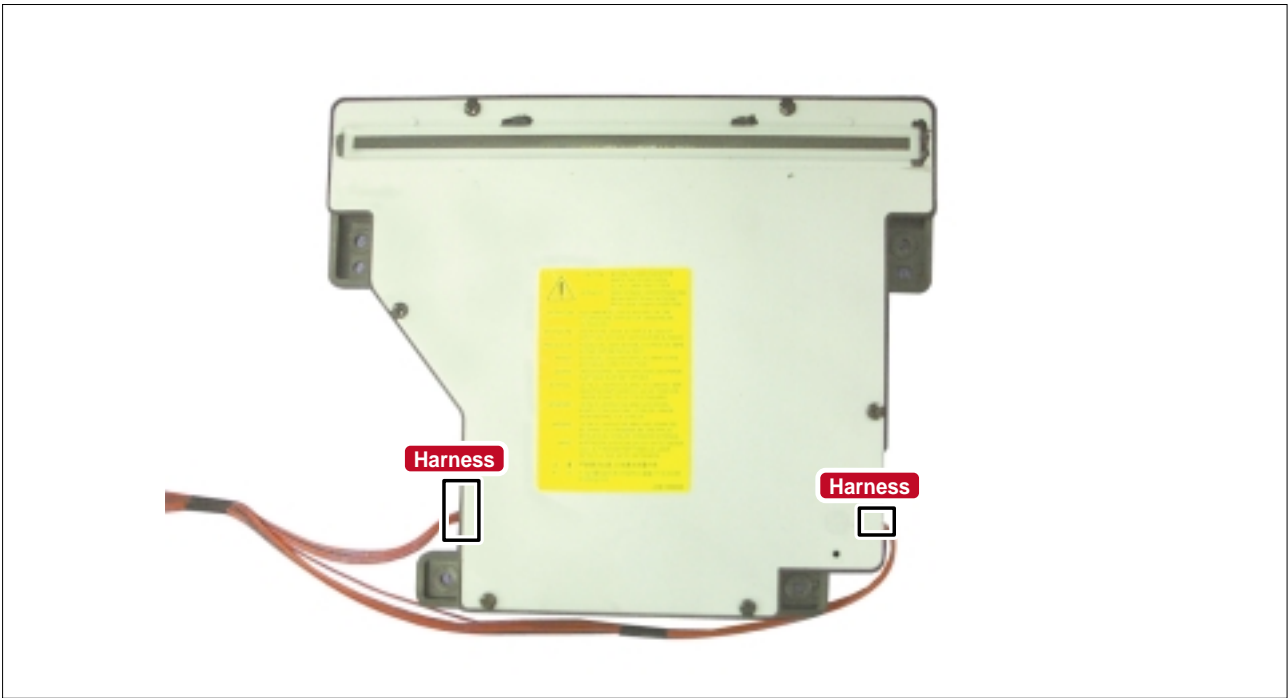

6.4.17 DEVE OEM PBA

>> Before disassembling it:

* Disassemble the **front cover** and the **top cover**. (Refer to 6.4.1)

- 1) Separate one harness(CN1) from the HVPS and one harness(CN2) from the DEVE OEM PBA.
Remove 6 screws (3*8 black) and then take out the DEVE OEM PBA.

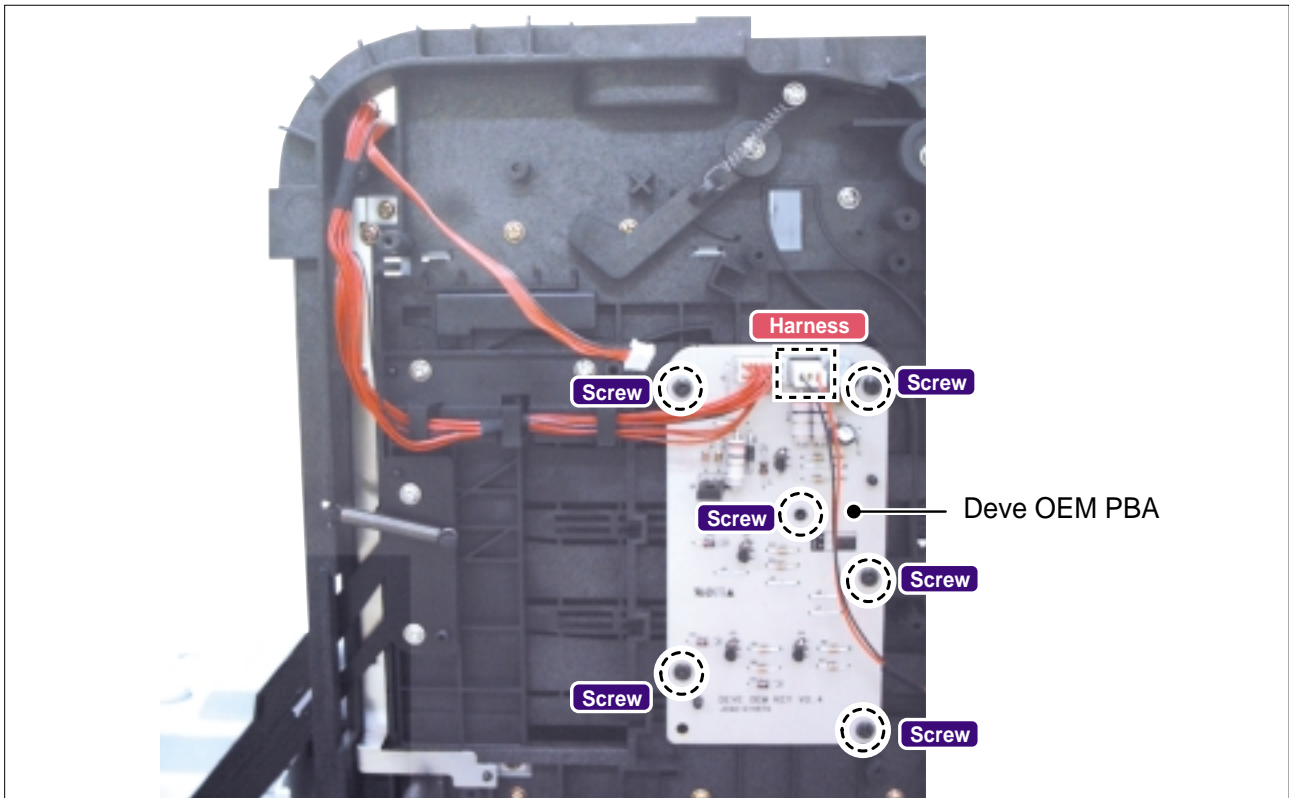

- 2) Remove 12 terminals.

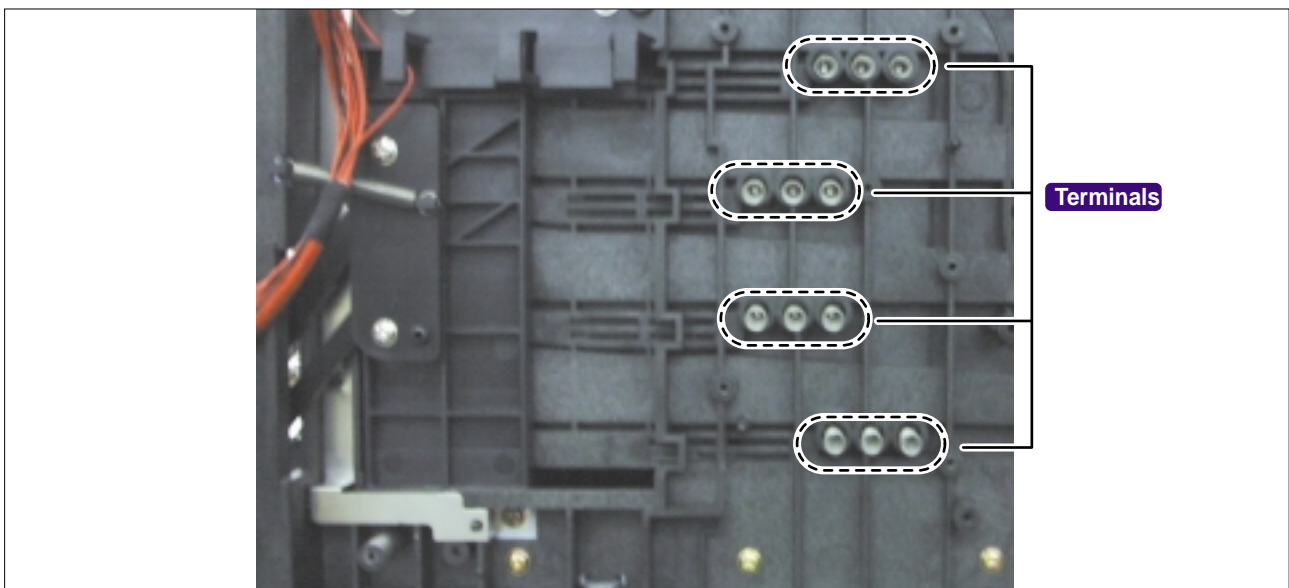

6.4.18 Waste toner ass'y

>> Before disassembling it:

* Disassemble a **front cover** and a **top cover**. (Refer to 6.4.1)

1) Release 6 screws (3*10 silver).

* Upper part: 4 screws * Lower part: 2 screws

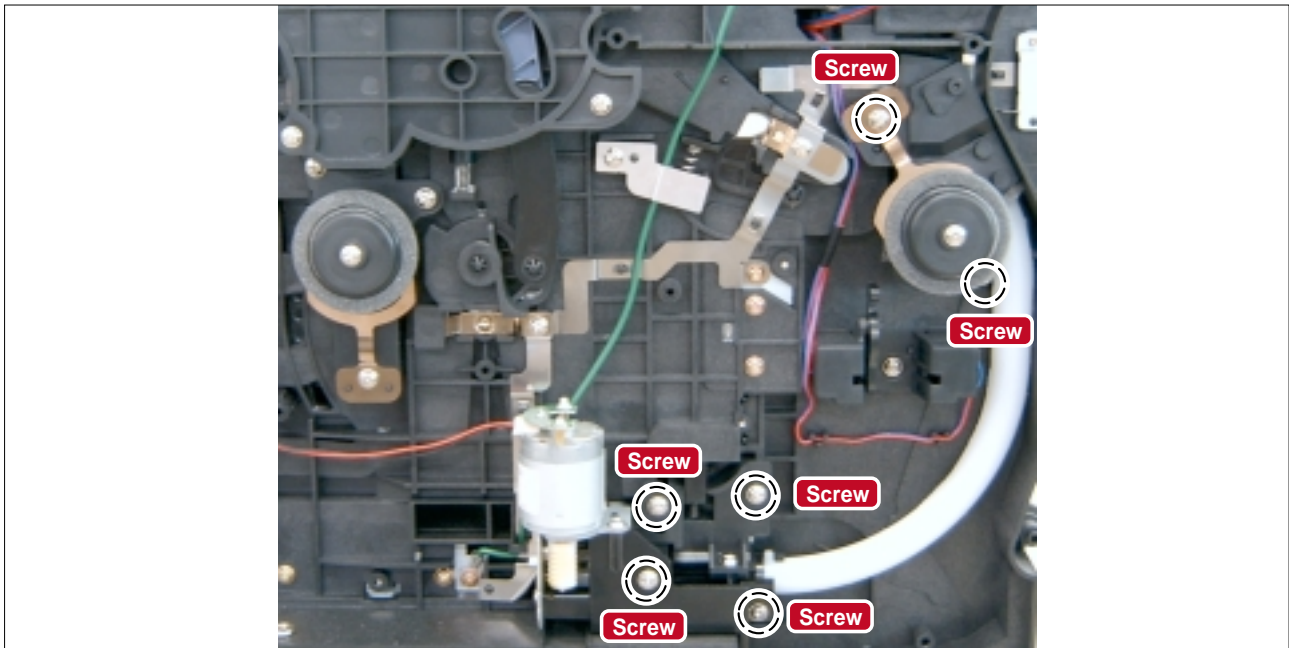

2) Remove the waste toner ass'y by first reaching into the OPC cavity and lightly depressing the waste toner receiver whilst at the same time gently pulling the waste toner motor ass'y away from the set. Once the ass'y is released refer to the photograph and remove the ass'y.



Caution: * It is very likely that waste toner will be spilled when removing the waste toner ass'y.

3) Release one screw (3*10 silver) and then remove the sensor cover.

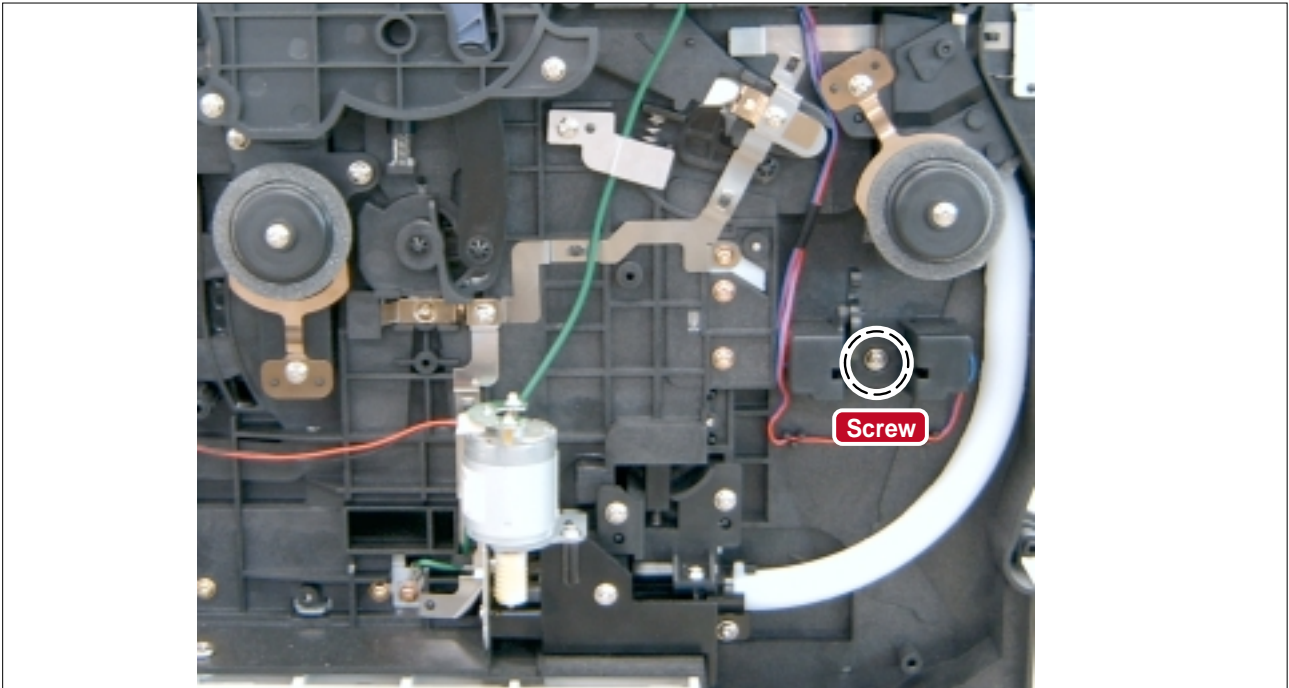

6.4.19 MPT(Multi Purpose Tray)

>> Before disassembling it:

- * Disassemble **all consumption parts** (Toner cartridge, ITB unit, and OPC drum) (Refer to 6.3.3)
- * Disassemble the **front cover** and **top cover** (Refer to 6.4.1)
- * Disassemble the **rear cover**. (Refer to 6.4.3)
- * Disassemble the **duplex cover**. (Refer to 6.4.4)
- * Disassemble the **SMPS & main PBA**. (Refer to 6.4.7)

1) Release 4 screws (3*10 silver)

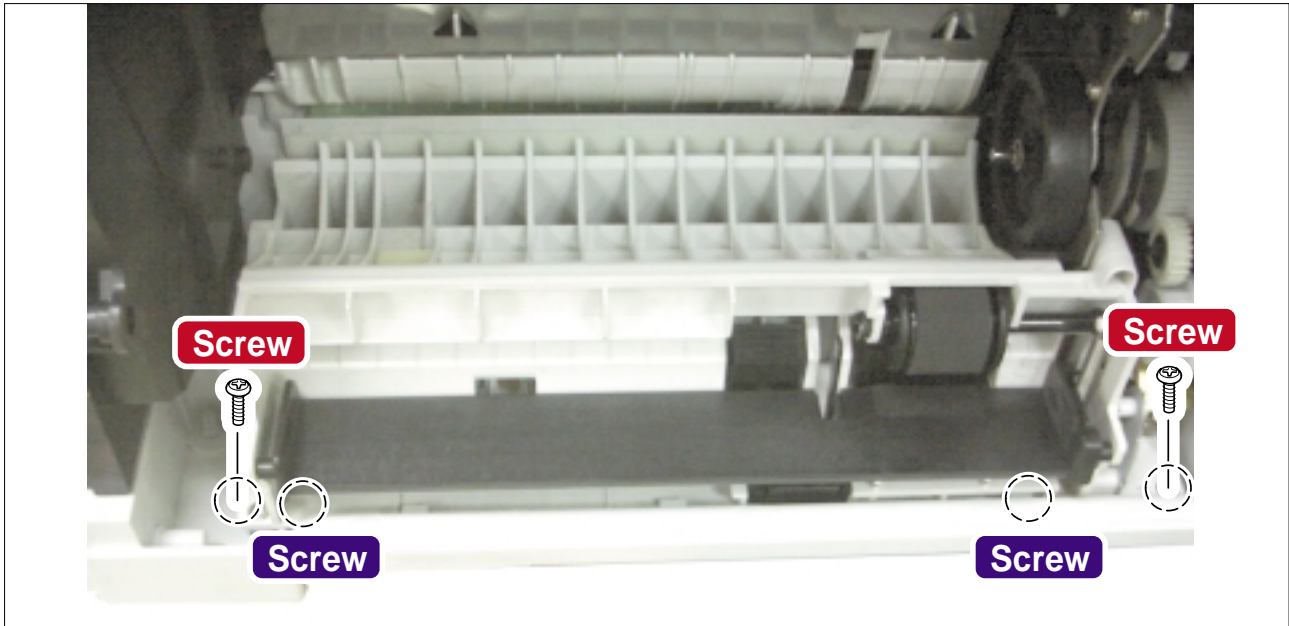

2) Release the 2 clips located underneath the machine (see photograph). Pull the MP Ass'y upward and release the assy.

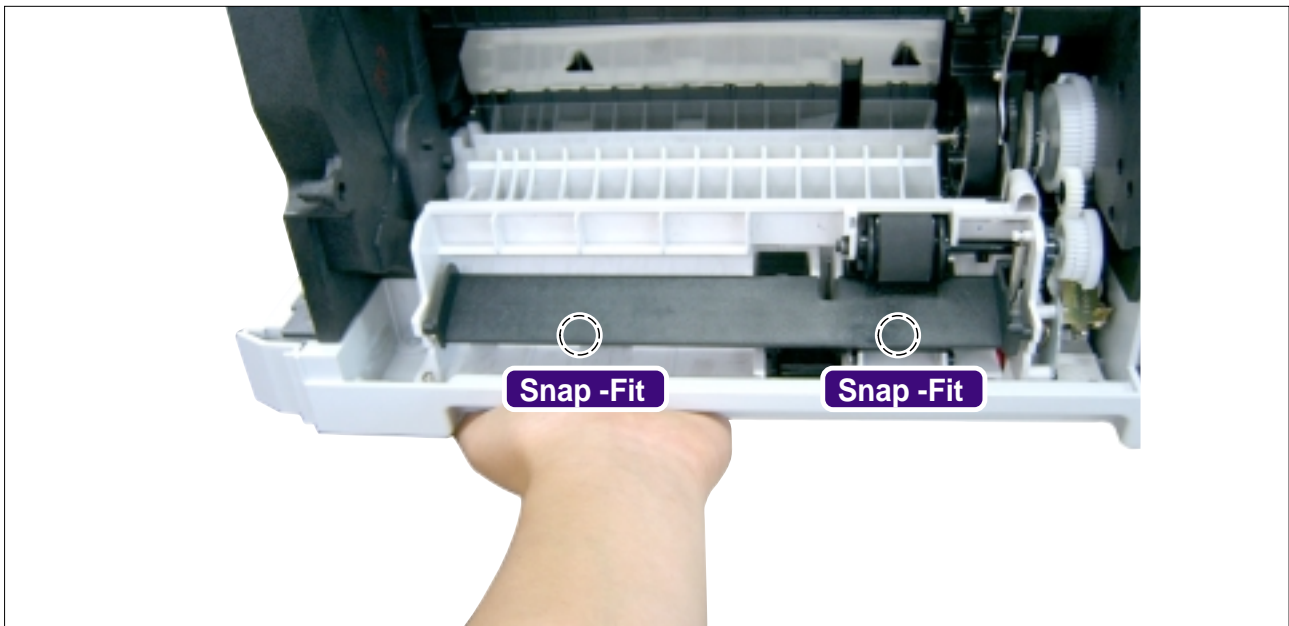

Note : it is not possible to remove the assy at this stage, take care not to put excessive strain on the cable harness.

6.4.20 Pick-Up Ass'y

>> Before disassembling it:

- *Disassemble all consumable parts (Toner cartridges, ITB unit and OPC drum) (Refer to 6.3.3)
- *Disassemble the front cover and top cover (Refer to 6.4.1)
- *Disassemble the rear cover. (Refer to 6.4.3)
- *Disassemble the duplex cover. (Refer to 6.4.4)
- *Disassemble the SMPS & main PBA. (Refer to 6.4.7)
- *Disassemble the Erase Lamp. (Refer to 6.4.14)
- *Disassemble the Waster Toner Ass'y (Refer to 6.4.18)

- 1) Undo 2 screws (3*10 silver) and remove the "Pick-up Solenoid". Then remove the plastic circlip which retains the Pick-Up Gear and also remove the gear wheel. Release the shaft retaining bearing.

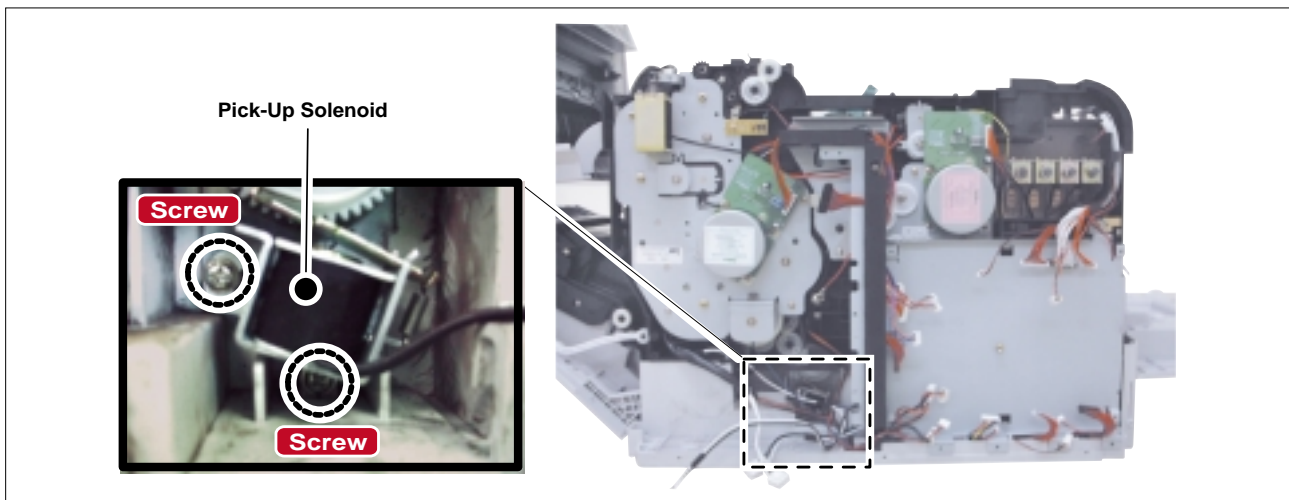

- 2) Remove the 3 screws (4*10 silver) in the "Pick-up Ass'y"

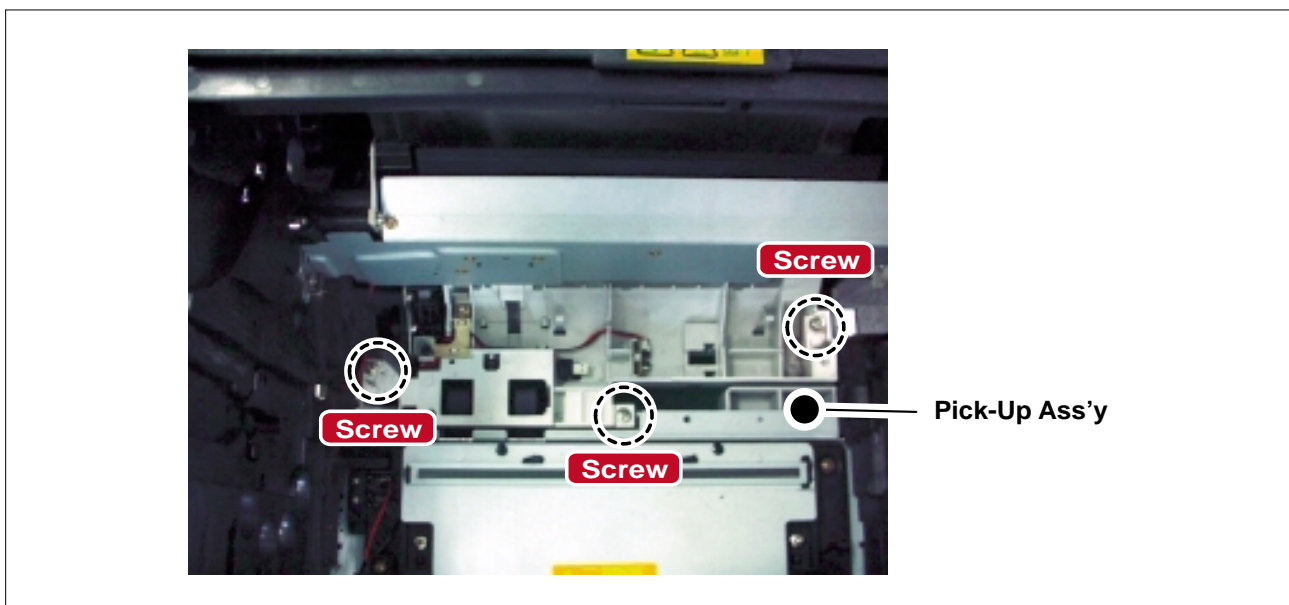

- 3) Remove the 3*8 black screw retaining the Guide Pick-Up plate. Using a small flat bladed screwdriver or similar tool force the brass ground plate off the retaining lugs and bend it upward slightly. Release the Eraser Lamp harness and paper Empty Sensor harness, these pass between the main engine frame and base frame and cannot be removed.

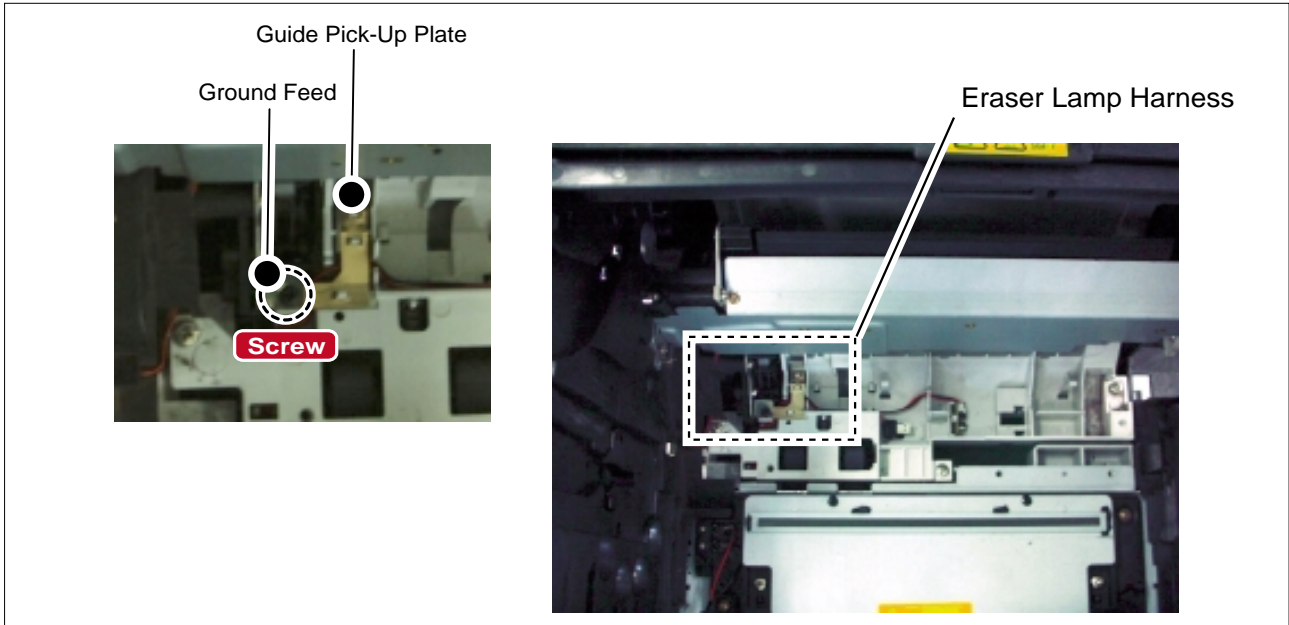

- 4) Remove the "ACTUATOR-EMPY (JC72-00465A)" sensor arm and then take out the "Pick-up Ass'y" by lifting the right hand side and sliding the shaft from the frame.

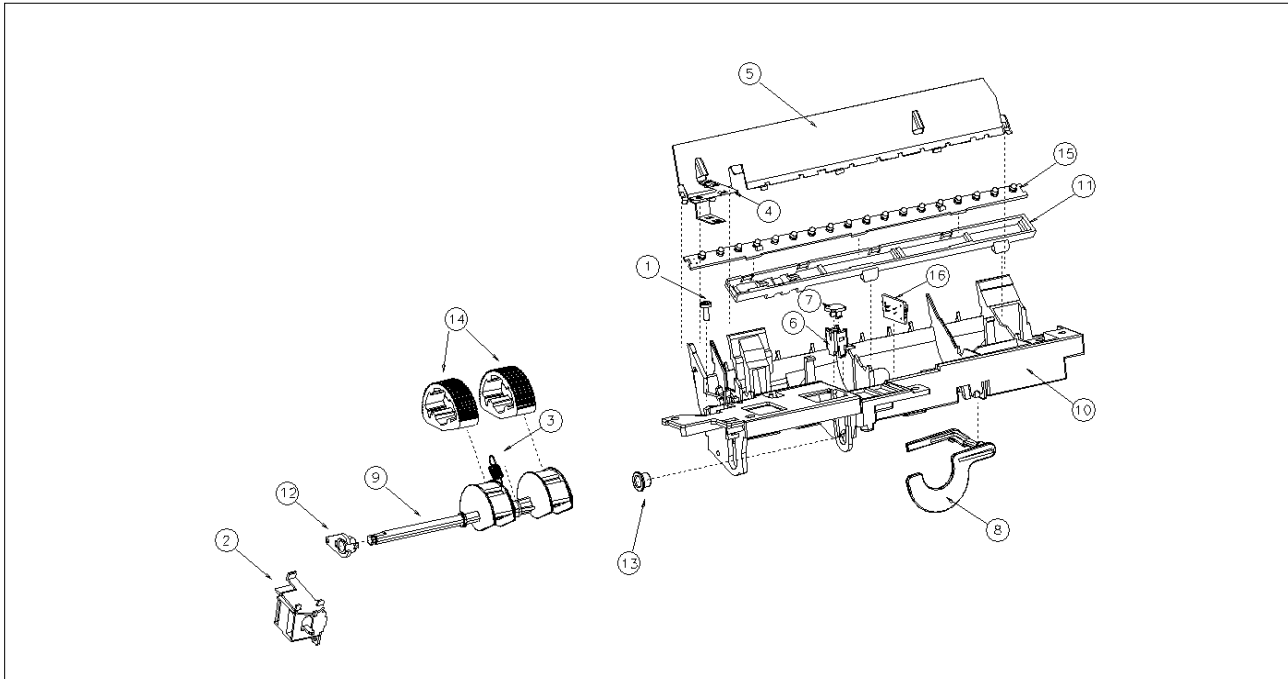

No.	Code	Description	Qt'y
1	6003-000119	SCREW-TAPTITE	1
2	JC33-00007A	SOLENOID-PICK UP	1
3	JC61-00482A	SPRING ETC-PICK UP	1
4	JC70-00359A	IPR-GROUND FEED	1
5	JC70-00360A	IPR-GUIDE INPUT	1
6	JC72-00463A	PMO-CAP CONNECTOR L	1
7	JC72-00465A	PMO CAP CONNECTOR U	1
8	JC72-00719A	PMO-ACTUATOR EMPTY	1
9	JC72-00729A	PMO-SHAFT PICK UP	1
10	JC72-01076A	PMO-GUIDE PAPER	1
11	JC72-01218A	PMO-HOLDER ERASER	1
12	JC72-41191A	PMO-BEARING SHAFT	1
13	JC72-41364A	PMO-BUSHING_P/U,MP	1
14	JC73-00149A	RPR-RUBBER PICK UP	2
15	MLC500-5538	PBA-ERASER ASS'Y	1
16	MLC500-5542	PBA-PAPER EMPTY ASS'Y	1

< Pick-Up Ass'y ExplodedView and Parts List >