

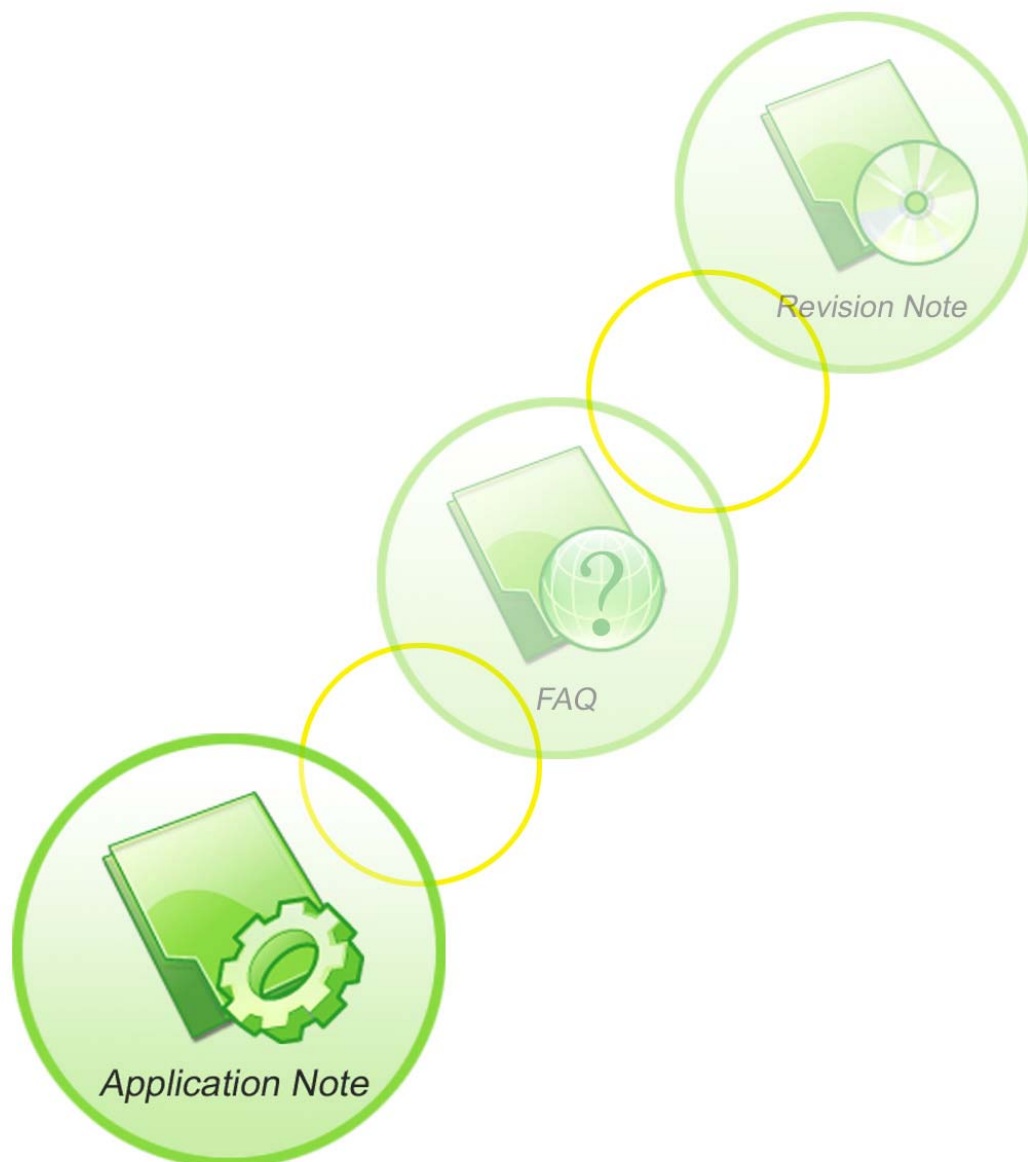

SIM900 Reference Design Guide

SIM900_AN_Reference Design Guide_V1.02



Document Title:	SIM900 Reference Design Guide
Version:	1.02
Date:	2010-08-14
Status:	Released
Document Control ID:	SIM900_AN_Reference Design Guide_V1.02

General Notes

SIMCom offers this information as a service to its customers, to support application and engineering efforts that use the products designed by SIMCom. The information provided is based upon requirements specifically provided to SIMCom by the customers. SIMCom has not undertaken any independent search for additional relevant information, including any information that may be in the customer's possession. Furthermore, system validation of this product designed by SIMCom within a larger electronic system remains the responsibility of the customer or the customer's system integrator. All specifications supplied herein are subject to change.

Copyright

This document contains proprietary technical information which is the property of SIMCom Limited., copying of this document and giving it to others and the using or communication of the contents thereof, are forbidden without express authority. Offenders are liable to the payment of damages. All rights reserved in the event of grant of a patent or the registration of a utility model or design. All specification supplied herein are subject to change without notice at any time.

Copyright © Shanghai SIMCom Wireless Solutions Ltd. 2010

Contents

Version history.....	4
1. Introduction.....	5
1.1 References Document	5
2 Application Interface.....	2
2.1 Power Supply Design	2
2.1.1 VBAT design	2
2.1.2 Battery Charge design	3
2.1.3 PWRKEY ON/OFF design.....	4
2.1.4 Reset design.....	4
2.1.5 RTC backup design	5
2.2. UART interface	5
2.2.1 UART interface design	5
2.3 GPIO selection	6
2.3.1 STATUS and NETLIGHT	6
2.3.2 GPIO.....	7
2.4 Audio interfaces	7
2.4.1 Referenced circuit of headset design.....	7
2.4.2 Referenced circuit of hand free design.....	8
2.5 Antenna matching circuit design	8
2.6 SIM card interface.....	9
2.7 ESD protection	10
2.8 Consideration in PCB layout.....	10

Version history

Date	Version	Description of change	Author
2010-01-01	1.01	First Release	Zhou Qiang
2010-08-14	1.02	§ 2.1.5 Add the description of VRTC connection	Zhou Qiang

1 Introduction

This document describes how to design peripheral interface of SIMCOM module provided in your application.

1.1 References Document

SN	Document name	Remark
[1]	SIM900_ATC	SIM900 AT command Set
[2]	SIM900_HD	SIM900 Hardware Specification
[3]	SIM900_EVB_UGD	SIM900 EVB User Guide
[4]	AN_SMT Module RF Reference Design Guide	SMT MODULE RF Design Guide
[5]	AN_SIM900-TE PCB Layout & Schematic for Reference	SIM900-TE PCB Layout Reference Design

2 Application Interface

2.1 Power Supply Design

2.1.1 VBAT design

The power supply of SIM900 is from a single voltage source of VBAT, its normal operating voltage is from 3.2V to 4.8V. The peak working current can rise up to 2A during maximum power transmitting period, which will cause a voltage drop. So the power supply must be able to provide sufficient peak current, if not, the voltage may drop lower than 3.1V, and the module will automatically power down. Typically, VBAT can be set to 4V.

SIM900 can be used in a wide range of application, the power supply design is deeply depending on the power source.

When the input is a 5V/2A adapter, a LDO linear regulator can be used in the design because the drop out between input and output is not so big. Figure 1 shows the recommended circuit with MIC29302. Please also pay attention to the heat dissipation of the LDO. Usually, pouring a copper plane on the PCB is an effective way to the heat sink problem of the power IC.

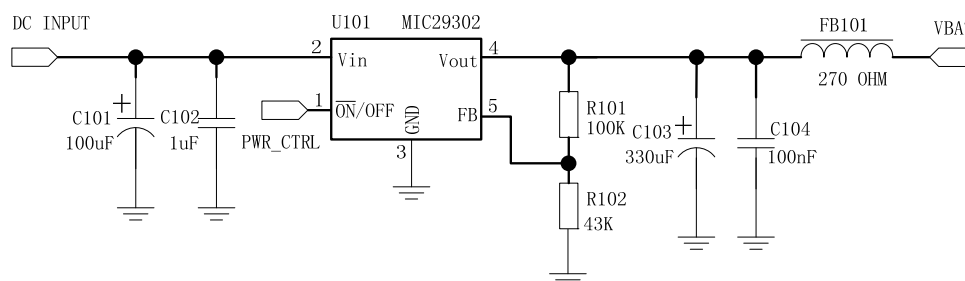

Figure 1: LDO Power Supply

NOTE 1:

The bypass capacitor C103 in Figure 1 is selected strongly depending on the rated current of the power source and the power IC. If both of the rated current are 2A, a low ESR tantalum capacitor (220uF or smaller) close to the VBAT pin is enough. Or user should change C103 to a bigger value according to the practical application. The rated current of the adaptor should not be less than 800mA (5V output).

The power IC and the bypass capacitor should be placed near the module, and the VBAT trace should be routed as wide and short as possible to reduce the PCB copper resistance when layout. If the power supply voltage is 12V or higher, a DC to DC converter is the best choice for its high efficiency.

When the module is powered by a DC-DC converter, user should pay more attention to the switching noise suppression design, otherwise the RF performance of SIM900 will be interfered by the switching noise of DC-DC, and it will cause some RF performance degradation, for

example, modulation spectrum or switching spectrum will exceed the limit. As a solution, a large current ferrite bead FB101 (0805 size package, rated current > 2A, low DC resistance) can be added between the DC-DC output and the VBAT input. By default, FB101 can be mounted with a 0 ohm resistor, and when necessary, it can be substituted with a large current ferrite bead. For a typical application in automotive device, following Figure 2 shows a reference circuit.

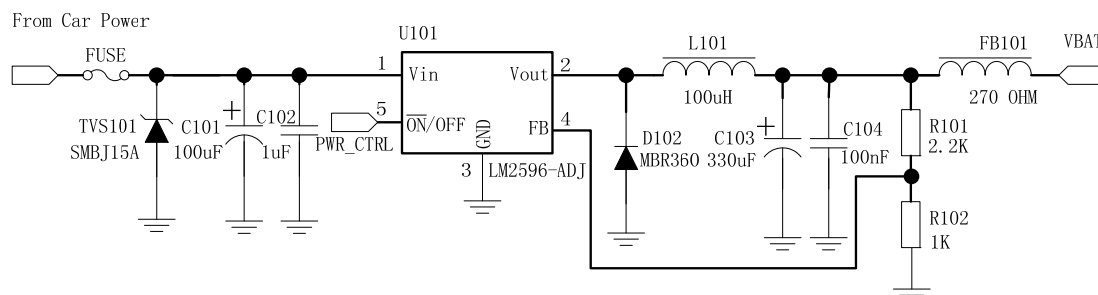

Figure 2: DC-DC Power Supply

When the input is from the USB port of a computer, the average current is 500mA according to the USB specification, so a super capacitor must be added near the module VBAT pins to compensate the peak current in transmit burst. A low ESR tantalum capacitor is usually used. The value for the capacitor should be more than 470uF.

2.1.2 Battery Charge design

SIM900 does not support the battery charge function. When the Li-ion battery is used in the application, a charger IC will be implemented. If the battery is only for backup (the AC adaptor is powered on most of the time), we suggest user to choose a charger IC with power-path management for battery lifespan. For example: BQ2407x series from Texas Instruments. Following figure 3 shows the reference circuit using BQ24075.

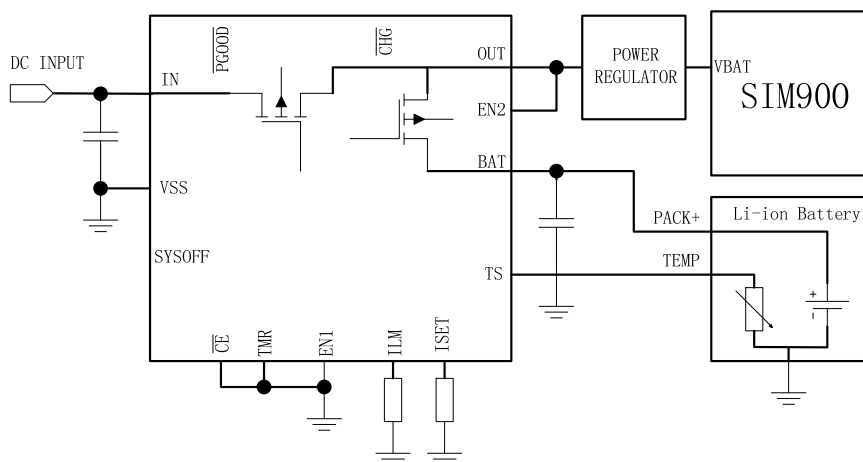

Figure 3: Battery Charge Supply

2.1.3 PWRKEY ON/OFF design

The simplest way to turn on/off SIM900 is to drive the PWRKEY to a low level for 1second then release. PWRKEY pin has been pulled up to 3V inside the module. Following figure is the recommended connection circuit with a NPN transistor. User can choose a GPIO of the MCU to control the POWER ON/OFF process. Please note that do not add a capacitor on PWRKEY pin, since it may cause some unexpected problems during the power on/off process.

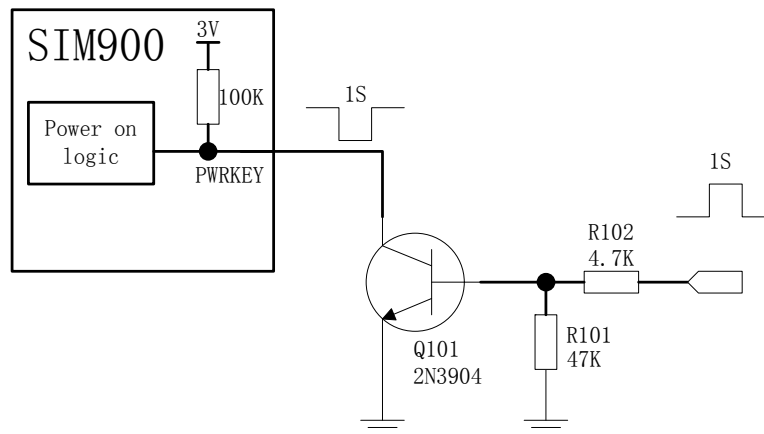

Figure 4: Turn on/off module using transistor

Another way to power on/off SIM900 is to connect PWRKEY and PWRKEY_OUT together. In this way, a P-channel MOSFET is needed. Therefore the first way of power on/off is recommended. In this way, PWRKEY_OUT should be kept open.

2.1.4 Reset design

SIM900 supports the reset function, when the MCU find the module is in an abnormal state, SIM900 can be restarted by pulling the RESET pin to ground for a typical 200mS. Reset is a noise sensitive pin, it should be kept away from the high speed signal line (eg. clock) when layout. This pin is internally pulled up to 2.8V through a 100k resistor, so it's not necessary to add an external pull-up resistor for stable consideration if it is not used. Please note that reset pin is only used in emergency situation, such as software break down, module not responding to the AT command. Reset the module frequently is not recommended and it may cause some unexpected fault.

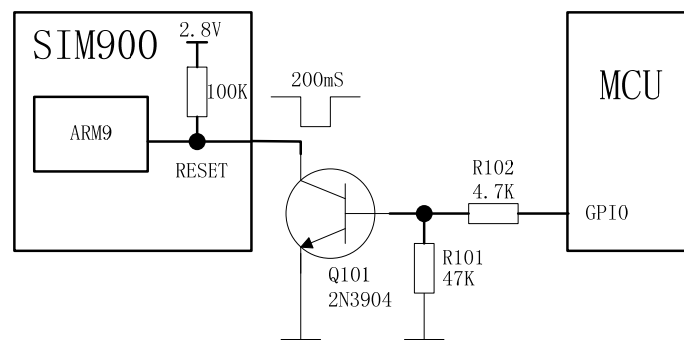

Figure 5: Reset SIM900 with a MCU

2.1.5 RTC backup design

SIM900 integrates a RTC backup interface which can be connected to a backup battery or a capacitor. The rated voltage of the battery should be 3V. The RTC current consumption is about 2uA when the VBAT is removed. Please note that do not keep this pin floating, if the back up time is not taken care of, a 4.7uF ceramic capacitor is recommended to be added between the VRTC pin of the module and GND.

2.2. UART interface

2.2.1 UART interface design

SIM900 integrates two UART port, one is called Serial Port, and the other is called Debug Port. Serial port is used to receive AT command from the MCU while Debug port is for firmware updating and bug trace. It is suggested to connect Debug port to an external connector for module debug and firmware upgrade consideration. If hardware flow control is not used, DCD, DSR can be left floating. Please refer to the following figure. DTR can be used to wake up the module from sleep mode and RI can be used to detect a coming call or SMS. These two pins should be connected to GPIO of the MCU.

NOTE 3:

Please note that the UART level is 2.8V, if the level is not matching, a level shift circuit is needed.

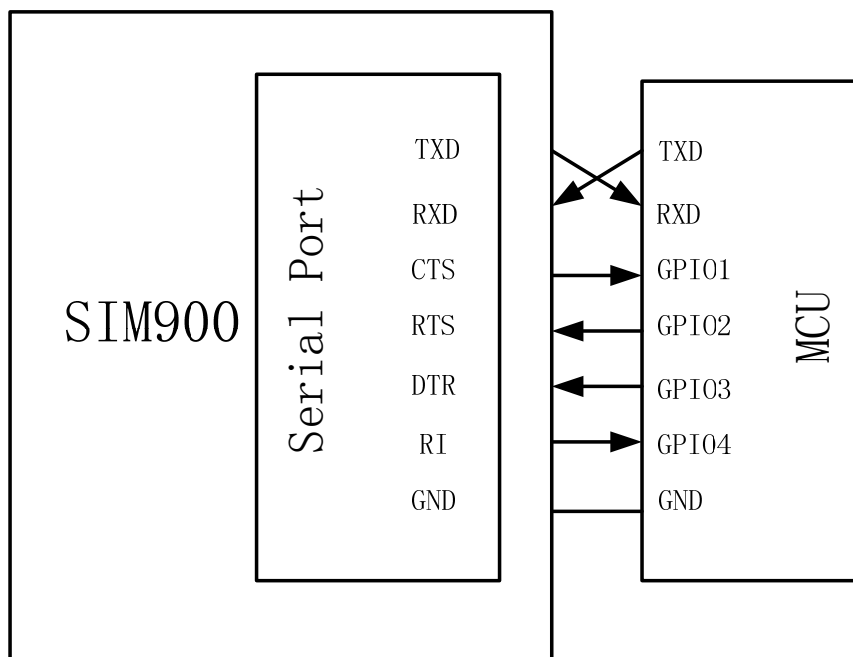

Figure 6: Serial Port Connection

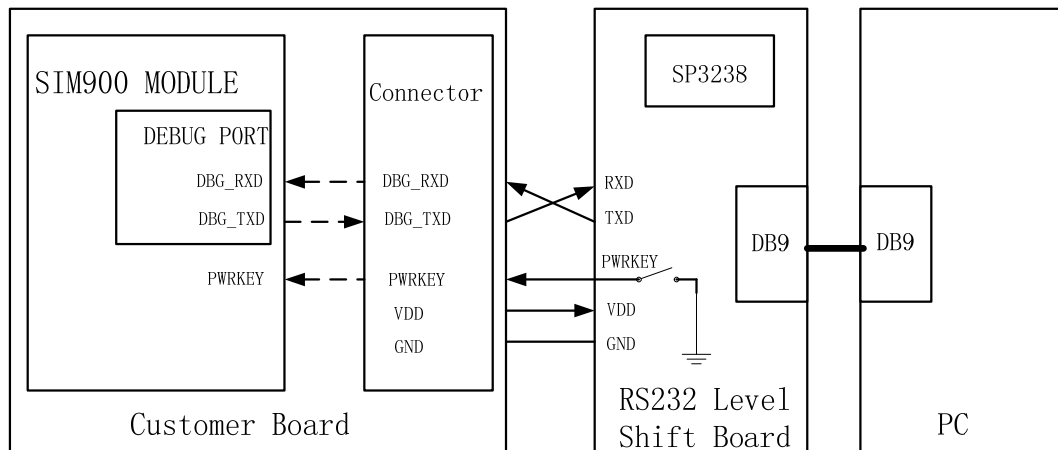

Figure 7: Debug/Upgrade Port Connection

2.3 GPIO selection

2.3.1 STATUS and NETLIGHT

STATUS pin can be used to monitor the module state during the power on/off process. After power up, AT command will not respond till the STATUS pin change to high, and STATUS pin will change to low after the module is logged off from the base station in a power down procedure. Status pin can be connected to a GPIO of the MCU.

NETLIGHT is a net status indicator. It can drive a transistor to control a LED which will blink slowly or quickly according to different states. Please note that it can not drive a LED directly. Both STATUS and NETLIGHT pins are dedicated in SIM900, they can not be used as a GPIO for the customer.

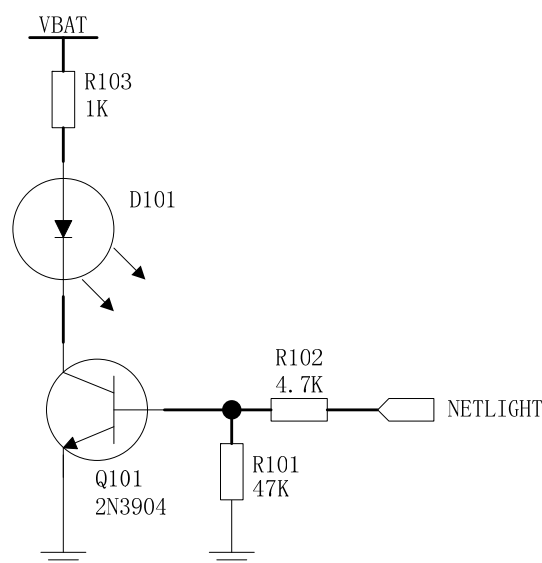

Figure 8: NETLIGHT indicator

2.3.2 GPIO

SIM900 provides 12 GPIOs which can be controlled by the customer. As a GPI, the status can be read by the AT command and as a GPO, it can also be controlled by the AT command. The customer can use this GPIO to achieve some simple control. For more detail, please refer to Document[1].

2.4 Audio interfaces

SIM900 provides a pair of differential analog audio channel, MICP & MICN can be connected to an electret condenser microphone directly and SPKP & SPKN can drive a 32 Ohm speaker. The maximum output power is 96mW. If the speaker impedance is 8 Ohm, user should add an audio amplifier between the module output and the speaker. We recommend National Semiconductor's LM4890. Also, the microphone input channel can be configured to a single ended mode. In this mode, the MICN can be left open. The negative terminal of the microphone can be connected to GND in the customer's board.

For adjustment, you can use AT+CMIC to set the input gain level of microphone, AT+CLVL to change the volume of the speaker. For details, please refer to [2].

2.4.1 Referenced circuit of headset design

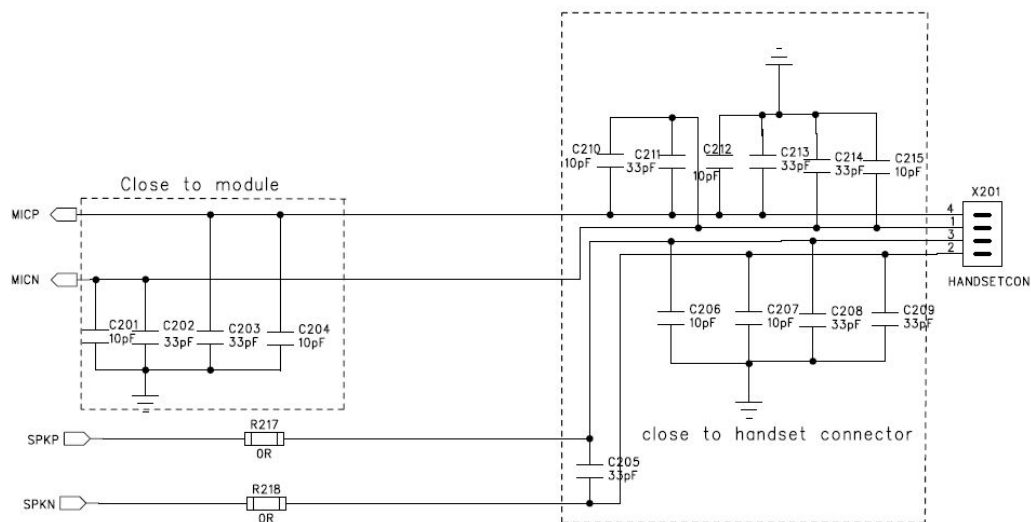

Figure 9: Referenced circuit of headset

2.4.2 Referenced circuit of hand free design

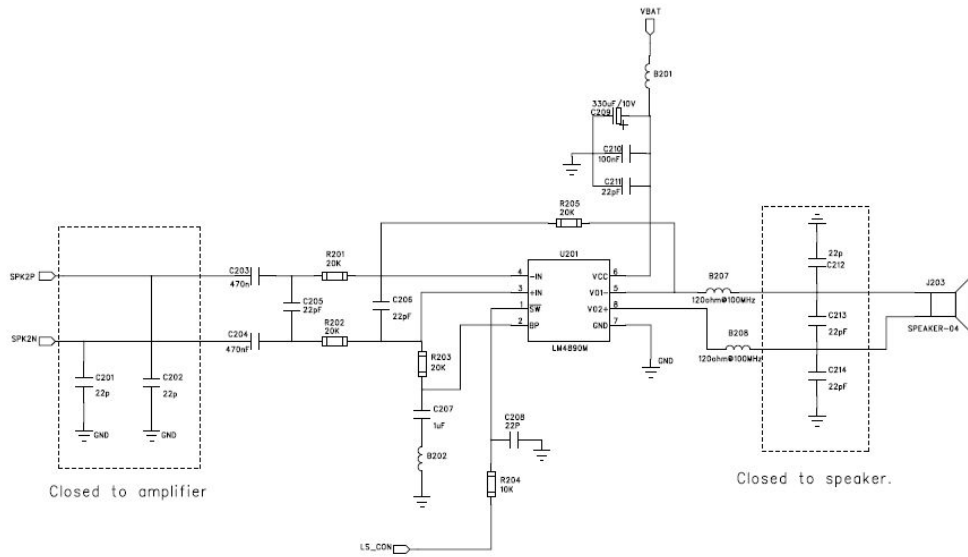

Figure 10: Referenced circuit of audio PA

2.5 Antenna matching circuit design

Because the module is working under 50ohm system in RF part, so, to get the best RF performance, the SMT module's load impedance should be tuned to 50ohm. But in fact most of the antenna's port impedance is not a purely 50ohm, so, to meet the 50ohm requirement, an additional antenna matching circuit should be added. Furthermore, to facilitate the antenna debugging and certification testing of RF performance, we suggested the customer add a RF test connector in series between the module's RF port and the antenna matching circuit. The recommended antenna matching circuit is shown as below:

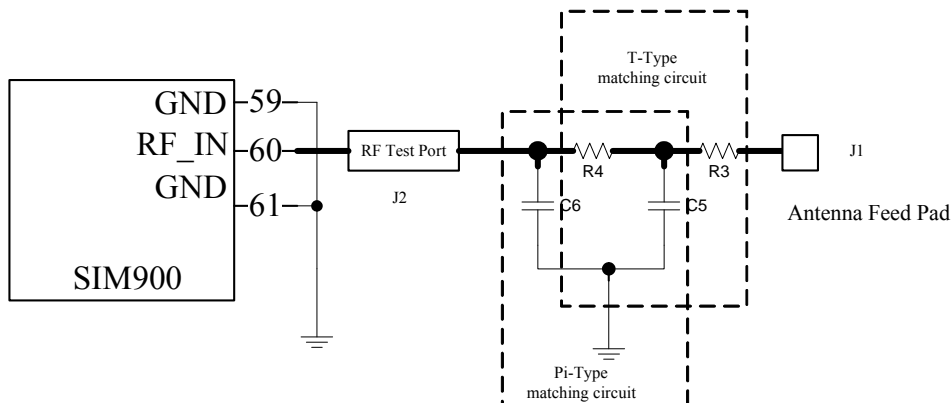

Figure 11: Antenna Matching Circuit

SIM900 Reference Design Guide Notes

In Figure 11, the components, R4, C5 and C6 make up a pi-type matching circuit structure. If users add the optional component R3, then a T-type matching circuit structure will be made up with another two components R4 and C5. But usually, a pi-type matching circuit is enough in antenna tuning process. The component J2 is a RF test Port, which is used for conducting RF test. The traces in Bold type must be 50 ohm impedance controlled when layout a design.

For the RF test connector, we suggested the customer use the part vended by Murata, its part number is MM8430-2610. For detailed information about this part, the customer can visit Murata's website: <http://www.murata.com>.

NOTE: For more detail on RF Layout design, please refer to Document[4]

2.6 SIM card interface

The SIM interface is powered from an internal regulator in the module. Both 1.8V and 3.0V SIM Cards are supported. You can select the 8-pin SIM card holder. The reference circuit with 8-pin SIM card holder illustrates as in the following figure. We recommend an Electro-Static discharge device ST (www.st.com) ESDA6V1W5 or ON SEMI (www.onsemi.com) SMF05C for ESD protection. The 22Ω resistor shown in the following figure should be added in series on the IO line between the module and the SIM card for matching the impedance. The SIM peripheral circuit should be closed to the SIM card socket.

The SIM_PRESENCE pin is used for detecting the SIM card. There is a 100k pull down resistor in SIM900 module. So the pull up resistor R110 should not be bigger than 10K. If user does not use the SIM card detection function, this pin can be kept open.

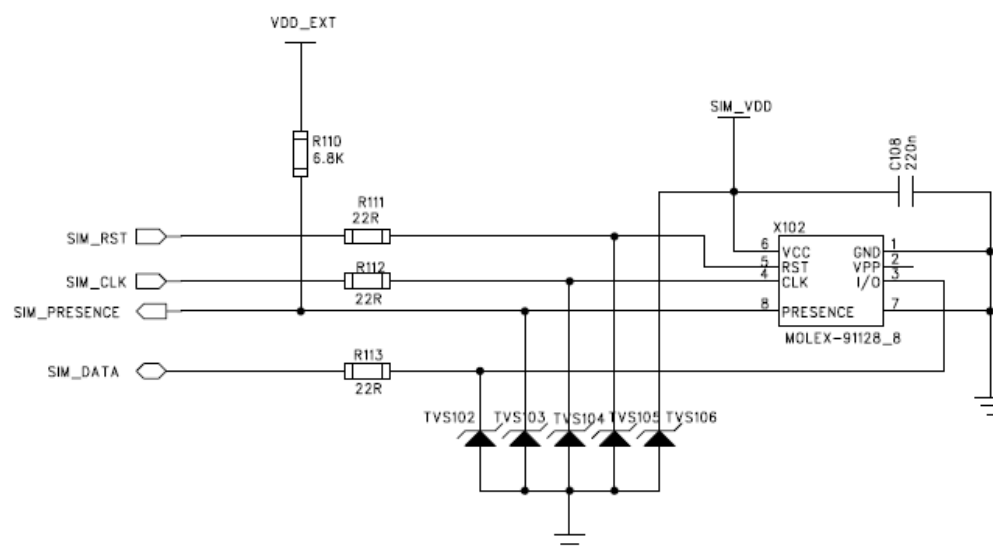

Figure 12: Reference circuit with 8-pin SIM card holder

Please note that SIM_DATA has already been pulled up to SIM_VDD in SIM900, so external pull up resistor is not necessary.

2.7 ESD protection

It is suggested that it's better to do some ESD protection in user's application to improve the ESD character of the module, especially for the signal connecting to external interface, for example, MIC, SPK, PWRKEY, VBAT, UART and SIMCARD.

2.8 Consideration on PCB layout

In SIM900's PCB design, a good PCB layout will help the improvement of the whole product performance, including reliability, EMC performance, etc. The following are some consideration for referenced:

- 1) The power trace should be short and wide, it is recommended to be routed above 80mil.
- 2) The layout of GROUND is very important. A whole ground layer is the best for module performance if it is possible. Some noise sensitive signal trace, eg. audio traces and reset trace should be shielded by ground.
- 3) The audio traces (MIC & SPK) should be better protected with ground. The width of MIC traces should be 6-8 mil and the SPK traces should be 10-12 mil. A differential pair routing is strongly recommended for these traces and keep parallel.
- 4) The test points at the bottom side of SIM900 module are for factory manufacture and testing only, not for customer's design. It is recommended that the area which is under the module's test points on the top layer of customer's main board should be copper keep out, otherwise it will be a risk of shorten to the GND vias, also it may decrease the RF character of the module.

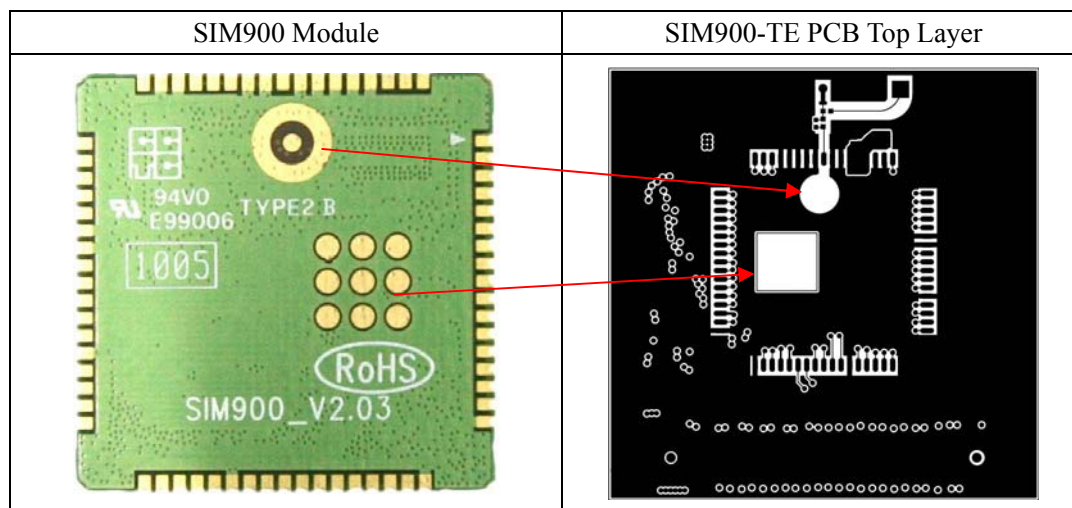

Figure 13: SIM900-TE PCB Layout

- 5) RF trace between SMT module RF pad with the RF test connector, RF trace between RF test connector with the antenna matching circuit, RF trace between the antenna matching circuit with the antenna feed PAD all should be controlled to 50 Ohm
- 6) Do not layout RF trace in orthogonal
- 7) When layout surface Microstrip Transmission Line or offset Stripline Transmission Line , 3W rule should be followed, that means the distance between reference GND with RF trace should be three times more than the width of RF trace.

For more detail information on RF layout design, user can refer to document [4] and [5].

Contact us:

Shanghai SIMCom Wireless Solutions Ltd.

Add: Building A, SIM Technology Building, No.633, Jinzhong Road, Changning District, Shanghai, P. R. China 200335

Tel: +86 21 3235 3300

Fax: +86 21 3235 3301

URL: www.sim.com/wm